



Dansensor® LeakPointer 3/3+

User Guide EN

This blank page has been inserted to enable double sided printing of the document!

Dansensor®
LeakPointer 3/3+

User Guide

EN

Published by:

MOCON Europe A/S
Rønnedevej 18
4100 Ringsted, Denmark
Tel +45 57 66 00 88
info.dk.mocon@ametec.com
www.ametekmocon.com

Table of Contents

- 1. Introduction..... 7**
 - General description..... 7**
 - Important! 8**
 - Safety and Use..... 8
 - About this Manual 8**
 - Intended Use of this Manual 8
 - Reservations..... 8
 - Notes, cautions and warnings! 9
 - Tips and recommendations 9
 - Overview 10
 - Accessories..... 12
 - Measuring principle 13
- 2. Setting up 15**
 - Moving/lifting 15**
 - Connections 16**
 - Main power supply cable 16
 - Compressed air..... 17
 - Network Cable..... 17
 - USB Connection 17
- 3. Operating 19**
 - Basics 19**
 - Switching on/off..... 19
 - Touch screen 21
 - Login and access levels 21
 - Restarting/resetting 21
 - Screen-shots 21
 - The Measuring screen 22
 - Pop-up messages..... 24
 - Menu navigation 25
 - Typing 27
 - Bar-code scanner 28
 - Printer..... 28
 - Get started 29**
 - Product setup 30**
 - Setting up products for “Single Package” testing..... 30
 - Setting up products for “Multi Package” testing..... 44

Measuring	47
CO2 levels	47
Selecting a product for measuring	47
Performing a workflow/measurement	50
Cleaning	54
General	54
Cleaning	54
4. Menus and Settings	55
Main menu	55
IMPORTANT!	55
Workflow	56
Products	56
Custom Fields	63
Access	65
Access levels	66
User Administration	67
Change Administrator PIN-code	69
Data	70
Collected Data	71
Collected data	72
Export	73
Service	74
Information	75
Diagnostics	75
Test & Adjustments	76
Settings	79
Export	80
Import	81
Network	82
Network Logging	83
Login	84
Device	85
Date/Time	86
Units	86

5. Technical Information.....87

Technical specifications87

- Mechanical specifications87
- Electrical specifications88
- Connectivity.....88
- Compressed air supply.....88
- Leak measuring.....89
- User Interface90
- Conformity.....90

Consumable parts and options91

- Ordering items91
- Available User Guides.....91
- Consumable parts91
- Options/Accessories91
- Printer.....91

Appendix93

Safety and handling instructions.....93

- Handling and maintenance93
- Repairing.....93
- Cables.....93
- Explosive atmospheres94
- Cleaning94
- Using connectors, ports, and buttons.....94
- Operating/storing temperatures and humidities.....94

Toxic and Hazardous Substances or Elements.....94

1. Introduction

General description

Dansensor® LeakPointer 3 and **Dansensor® LeakPointer 3+** are table top off-line leak testers for Modified Atmosphere Packages (MAP).



The devices can fast and easily discover seal integrity problems on most types of modified atmosphere packages with a minimum of 10% CO₂ in the gas mix.

The devices operate with a very simple measuring principle:

A CO₂ filled package is placed in a chamber in which a vacuum is built up. If there is a leak in the package, the gas from the package will leak into the chamber, thus the increase in the CO₂ content can be measured.

The PackFix mechanism (available either as standard built-in or as a retrofitted option) enables the devices to detect a leak and to calculate the leak size (according to the leak size definitions of the Dansensor® Leak Simulation Kit).

All measurement data can be saved in the device's database and exported for further analysis.

Important!

Safety and Use



WARNING! Personnel operating and maintaining the device must be familiar with all aspects of its operation and be proficient in maintenance.

Such personnel should review the information in "***Safety and handling instructions***" on **page 93** to promote safety awareness.

Failure to follow the safety instructions could result in fire, electric shock, injury, or damage to Dansensor® LeakPointer 3/3+ or other property.

- Prior to using the equipment it is assumed that it has been properly installed and configured as described in this manual.
- Always refer to this manual before operating or maintaining the device.
- Observe all NOTES, CAUTIONS and WARNINGS - see **page 9** for details.

About this Manual

Intended Use of this Manual

- This manual describes the common use and maintenance procedures of the **Dansensor® LeakPointer 3/3+** device. It is intended for the daily users and should be kept with the equipment for reference at all times.

Reservations

- This manual was written and illustrated using the best possible information available at the time of publication.
- Any differences between this manual and the equipment reflect improvements introduced after the publication of the manual.
- Changes, technical inaccuracies and typographic errors will be corrected in subsequent editions.
- As a part of our policy of continuous improvement, we reserve the right to alter design and specifications without further notice.

Notes, cautions and warnings!

Throughout the manual notes, cautions, and warnings are indicated with various icons and written in bold like the example below:



CAUTION! Never use hard tools or abrasive materials when cleaning any part of the device.

Explanation



NOTE! The operator should observe and/or act according to the information in order to obtain the best possible function of the equipment.



CAUTION! The operator must observe and/or act according to the information in order to avoid any mechanical or electrical damage to the equipment.



WARNING! The operator must observe and/or act according to the information in order to avoid any personnel injury.

Tips and recommendations

Tips, recommendations and “best practise” advises are indicated as shown in the example below:



TIP! If a new product will be very similar to an existing product, you might want to use the “Copy Product” function.

Overview



- 1 Vacuum Chamber**
Inside the vacuum chamber the actual leak testing is performed.
- 2 PackFix** (either built-in as standard or as retrofitted option)
The PackFix mechanism helps creating a positive pressure (Delta P) inside the package, making it possible to determine the actual leak size.
- 3 PackBase** (only on models with PackFix)
The PackBase can be used to elevate the package to ensure optimal compression of the PackFix mechanism **2**.
- 4 Chamber sensor**
The sensor detects when chamber is open and closed respectively.
The chamber sensor consists of a magnet built into the chamber sealing and a sensor located below the base plate.
- 5 5.7" colour touch display**
For intuitive operation of the device by use of explanatory icons and easy understandable text messages and buttons.
- 6 USB (2.0 - Type A) connector** 
For connection of a USB memory stick for exporting/importing of files and updating of firmware or for auxiliary equipment such as a bar-code scanner, an external keyboard and/or a printer.
The connector is fitted with a water-proof cover.
- 7 PackTray** (option)
The PackTray can be used when testing multiple packages simultaneously.



8 LAN/Ethernet port 

For connection to local computer network for external data collection (LAN Data dump).
The connector is fitted with a water-proof cover.
The port has 2 built-in status indicator LED's.

9 Connector for compressed air *(LeakPointer 3 models only)*

10 Main power connector with built-in On/Off switch and fuse holder

11 Delta P connector

Connector for the measuring hose used for Delta P measurements.

Accessories

The following accessories are included:



-
- 1 Power supply cable**
For connecting the device to a power outlet - the appropriate connector for the wall outlet is not included in the delivery.
-
- 2 Septa (100 pcs.)**
When performing pressure measurements in a package for product setup purposes, a septum should be applied to the package in order to ensure a leak free gas extraction and to protect the package from tearing at the piercing point - see "[Product setup](#)" on [page 30](#) for details.
-
- 3 PackBase mesh** (*models with PackFix only*)
Use the mesh together with the legs **4** to adjust the PackBase for a specific package type - see "[Adjusting the height of the PackBase](#)" on [page 38](#) for details.
-
- 4 PackBase legs (4 sets)** (*models with PackFix only*)
Use the legs together with the mesh **3** to adjust the PackBase for a specific package type - see "[Adjusting the height of the PackBase](#)" on [page 38](#) for details.
-
- 5 Needles (10 pcs.)**
For measure hose **7**
-
- 6 Leak Simulation Kit**
For gain adjustment measurements - see "[Determination of the Leak Correction Factor](#)" on [page 34](#) for details.
-
- 7 Measure hose, Delta P**
For performing pressure measurements in a package - see "[Product setup](#)" on [page 30](#) for details.
-

Measuring principle

The actual leak testing takes place inside the vacuum chamber. The procedure is as follows:

Without PackFix (Single Package or Multi Package)

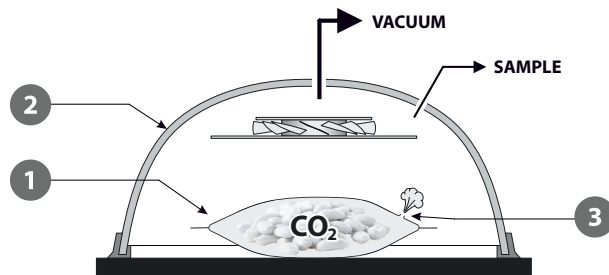

1. The package ① is placed in the chamber ② and the measurement sequence starts when the chamber is closed.
2. When vacuum builds up inside the chamber, the package will expand, thus creating a positive pressure (Delta P) inside it and if there is a hole ③ in the package, CO₂ will leak from inside the package and out into the chamber.
A sample pump sucks gas from the chamber through a sensor that detects the increased CO₂ level and reports it as a leak.
3. Since this type of measurement is not made on the basis of a predetermined Delta P value, the measurement result will be stated as the increase in the CO₂ level measured in the chamber (in ppm/s).
4. When the measurement is complete, the vacuum is released from within the chamber and the chamber ② opens.

With PackFix (Single Package only)

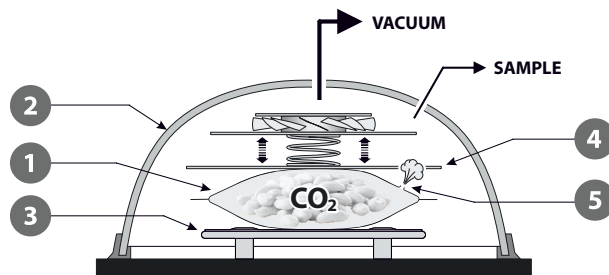

1. The package ① is placed in the chamber ② and the measurement sequence starts when the chamber is closed.
2. When vacuum builds up inside the chamber, the package expands and pushes against the PackFix mechanism ④. This creates a consistent positive pressure (Delta P) inside the package and if there is a hole ⑤ in the package, CO₂ will leak from inside the package and out into the measuring chamber.
A sample pump sucks gas from the chamber through a sensor that detects the increased CO₂ level and reports it as a leak.

3. The measurement result is converted to a fictive hole size (in μm) corresponding to a standard round hole in a 0.13 mm thick foil (if device is calibrated using the optional "Leak Simulation Kit" accessory - see "*Options/Accessories*" on page 91).
This does not mean that a hole of this size exists in the package, instead there could be 3 holes in the package, and together they correspond to the calculated standard hole size.
4. When the measurement is complete, the vacuum is released from within the chamber and the chamber ③ opens.

2. Setting up

Moving/lifting



CAUTION! When lifting or moving the device, this should be done by 2 persons grabbing the device underneath the bottom in each side.

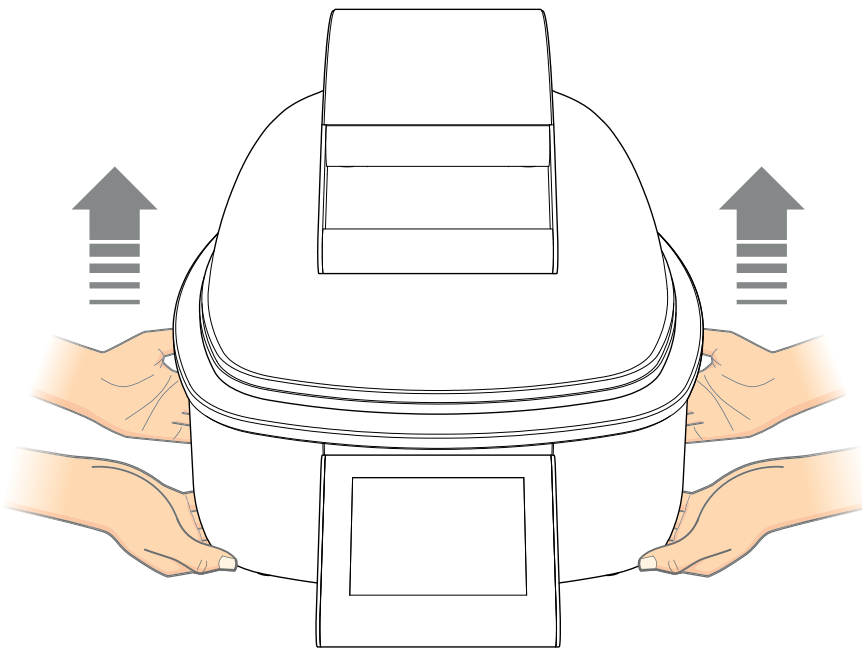

CAUTION! Never tilt the LeakPointer 3+ device more than 45 degrees in any direction relative to the horizontal, as this may cause the oil in the vacuum pump to enter the pump's vacuum chamber, which can cause serious damage to the pump impeller.



CAUTION! The vacuum pump in LeakPointer 3+ exhausts through a hole in the bottom plate. This hole must **NOT** be blocked.



NOTE! Place the device on a stable and even surface and ensure that the height of the surface allows for convenient operation as well as easy loading and removal of test samples.

Connections

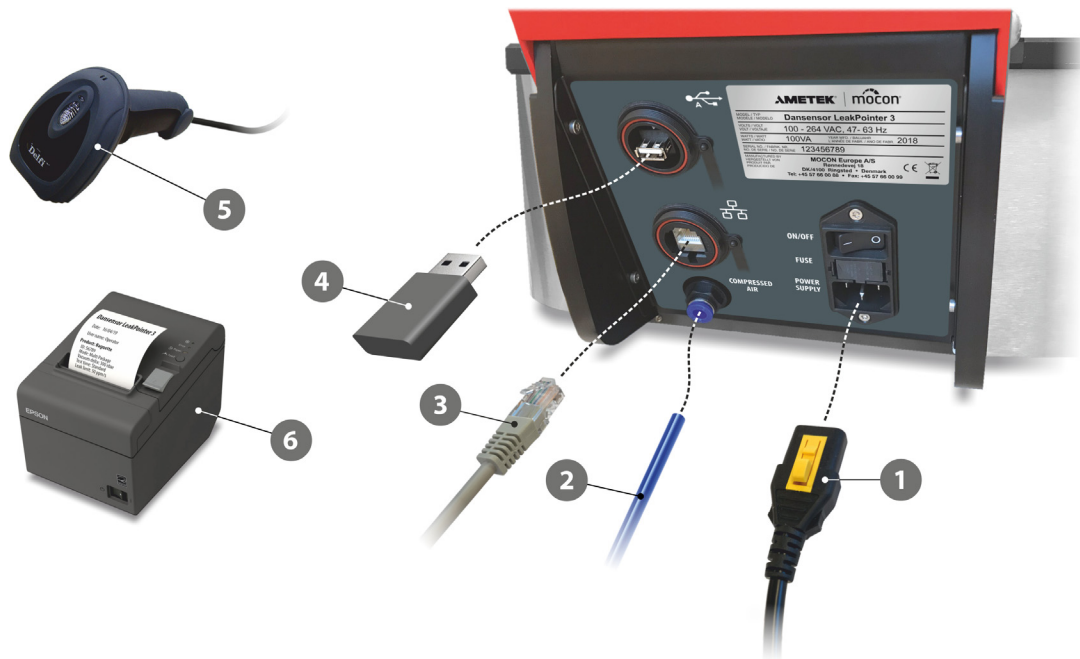

Main power supply cable



CAUTION! The main power supply cable must be prepared by authorized personnel.

The enclosed main power supply cable ① is provided “open-ended” (i.e. without mains plug). Install a mains plug that meets the local requirements.



WARNING! The ground wire (green/yellow) must always be connected to the local safety ground system in accordance with the local requirements.

Alternatively a standard power cable (C14 acc. to IEC 60320-1, UL 498 or CSA C22.2 no. 42) with a local mains plug can be used.

Minimum rating must be in accordance with the requirements - see *"Electrical specifications" on page 88*.

Connect the cable between a suitable power outlet and the device's "POWER SUPPLY" connector. Make sure that the yellow locking mechanism locks the cable in the connector (pull the cable gently to check).

Compressed air

(LeakPointer 3 only)

Connect a compressed air supply hose ② to the "COMPRESSED AIR" inlet.

Make sure

- that the hose between the device and the pressure regulator is max. 1m, otherwise you must compensate for the pressure drop in the hose.
- that the hose is pushed into the fitting as far as it goes
- to check the connection by pulling the hose slightly outwards
- that the hose and the compressed air complies with the specifications as specified in *"Compressed air supply" on page 88*



CAUTION! When connecting the hose, make sure that it can not be squeezed or blocked in any way.



CAUTION! If the specified maximum pressure is exceeded, there is a danger of bursting of tubing and other components.



NOTE! If the air supply pressure is below or above the specified input pressure, the system may not function as intended.

Filter recommendations

It is recommended to install a filter with a degree of filtration down to 5µm.

Network Cable

If you plan on using network data logging, you should connect a LAN/Ethernet cable ③ from the LAN connector (labeled ) to a connector on your local area network. This cable is not delivered with the device.



NOTE! Use shielded cables for optimal noise immunity.



NOTE! Always consult your network administrator before making network settings, as incorrect settings can result in reduced or no network activity.

USB Connection

The device has two USB connectors (labeled ) , one on the backside and one on the front below the control panel.

They can be used for connecting a USB Memory stick ④ for exporting/importing log data, device settings etc. and for connection of a bar-code scanner ⑤ and/or a printer ⑥.

3. Operating

Basics



CAUTION! If the device is operated in a cold and high humidity environment it is advisable to let it heat up for 5-10 minutes after it has been switched on.

Switching on/off

1. Use the ON/OFF button on the back of the device to switch the device on and off.
2. When the device is switched on, the splash screen is displayed for a few seconds while device is initializing. The screen shows the currently installed firmware version **1**.



3. When the device is ready and if no login is required, the display will show:



Current user is the default **Operator**.

4. If, however, login is required the **Access** menu appears.

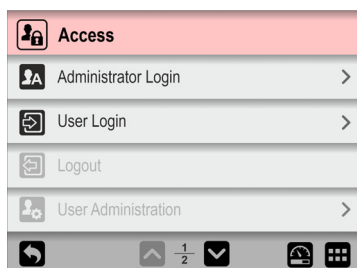

5. Select **User Login** and then either select a user from the **User Login** list or enter a valid **User ID** whatever is required.



6. When the device is ready, the display will show:



Current user is as selected during login with the access level as specified for this user (👤 **Standard Test Operator** or 👤 **Operator**).



NOTE! At this point even users created with "Supervisor" access will also only have "Operator" access.
See how to obtain "Supervisor" rights in ***Supervisor login*** on page 66.

Touch screen

Except for the ON/OFF button on the back of the device, all the buttons you use are virtual ones on the touch screen.



CAUTION! The touch screen should only be finger touch operated. Pencils or metal tools can damage the touch sensitive film.

Login and access levels

Different levels of login can be selected, and all users can be assigned different levels of access, some of which only allow access to a limited number of the device's functions and menus - see "[Login](#)" on page 84 and "[Access](#)" on page 65 for details.

Restarting/resetting

If device freezes or something is not working right, try switching the device off and then on again using the ON/OFF button on the back of the device.

Screen-shots

The device offers the ability to take screen-shots of current screens. This can be useful for example in connection with remote support. The screen-shots can be exported to a USB-stick - see "[Export](#)" on page 73 for details.

To make a screen-shot, tap 5 times in quick succession on the top part of the screen.



The Measuring screen

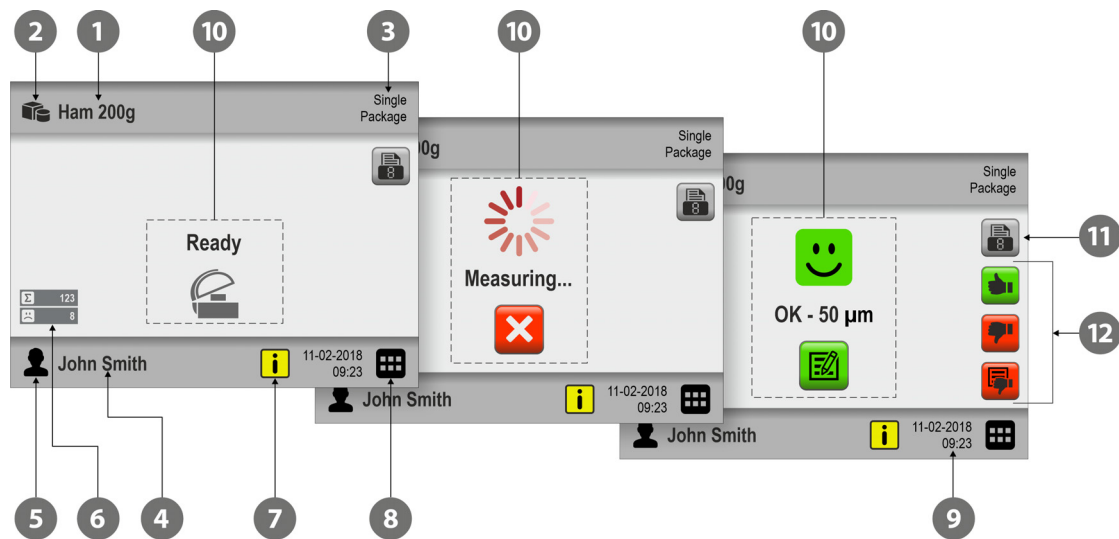

1	Active product	Currently selected product. To select another product, tap Products icon 2.
2	Products icon	Pressing this icon will take you to the Products menu for quick selection of a product. See " Selecting a product for measuring " on page 47 for details.
3	Measuring mode	The measuring mode for the currently selected product.
4	Current user	Currently selected user. To select another user, press User icon 5.
5	User icon	This icon shows the access level of the current user: <ul style="list-style-type: none"> 👤 Standard Test Operator 👤 Operator 👤 Supervisor 👤 Administrator 👤 Service See " Access " on page 65 for details about users and access levels. Pressing this icon will log out the current user and take you to the Access screen from where you can select another user or login as Administrator .

-
- 6 Statistics counter**

The counter shows the number of completed tests (☒) for the current product as well as the number of leaks found (☒). The counter is only displayed when the device is in **Ready** mode.

The counter counts up to 9999 after which it starts again from 0, and it resets if the device is switched off and on again or if another product is selected.



However, it is possible to reset the counter for the currently selected product if the same product is selected again.

 - 7 Calibration alert**

 Next calibration in 1 - 30 days



 Calibration period expired/exceeded

Pressing the icon displays a pop-up window with information about the calibration alert:



Info (XXXX)

Next calibration in 24 days





Warning (XXXX)

Calibration exceeded 2 days



 - 8 Menu icon**

Pressing this icon will take you to the  **Main Menu**. See *"Main menu" on page 55* for details.

 - 9 Date & Time**

Current date and time.



 - 10 Status area**

In the status area the workflow status/progress is displayed. See *"Performing a workflow/measurement" on page 50* for details.



 - 11 Print**

All measurement data can be printed continuously on a connected USB-printer - see *"Printer" on page 28* for details. Press the button to edit the required number of print-outs (0-9). The button shows the currently selected number of print-outs.

 - 12 Acknowledge Measurement buttons**

The buttons appear on the measuring screen if  **Acknowledge Measurement** is enabled in  **Main Menu** ->  **Workflow**

Press the appropriate button after performing a measurement to

 -  Validate measurement
 -  Mark measurement as invalid
 -  Mark measurement as invalid and apply additional comment

The choice determines how the measurement is recorded in the collected data list - see *"Collected data" on page 72* for details.

Pop-up messages

Three types of messages may occur:

- **Info**
- **Warning**
- **Error**



Generally the **Info** and **Warning** messages are self explanatory and relates to user interface interaction. They must be acknowledged by tapping or by tapping or to decide how to proceed.

Error messages are mainly related to the device itself. The **Error** message screen describes the problem and must be acknowledged by tapping .

If one or more errors persist you should contact your service provider (see "[Service](#)" on page 74).

In these cases be sure to inform of the error no. as indicated in the header of the **Error** message screen.

A list of the most recent errors is available in the **Error/Event Log** from the **Data** menu - see "[Data](#)" on page 70 for details.3

Menu navigation

The graphic interface offers various elements for navigating through the menu structure:

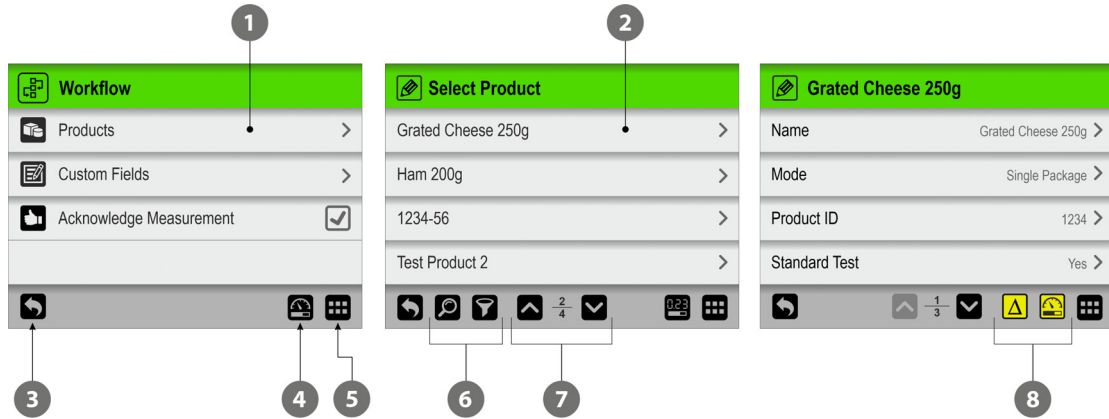

1	Submenu	Open the associated submenu.
2	Open product	Select and open the product record.
3	Return icon	<ul style="list-style-type: none"> Return to the previous menu level. Save editing and return to previous window. When editing products and users, tapping the button will save the edited product or user when confirmed.
4	Measure icon	Pressing this icon will take you to the measuring screen. See <i>"The Measuring screen" on page 22</i> for details.
5	Main Menu icon	Pressing this icon will take you to the Main Menu . See <i>"Main menu" on page 55</i> for details.
6	Find/Filter icons	Opens the Find and/or Filter function - see <i>"Find and Filter" on page 61</i> for details.
7	Scroll/Current page	Tap icons to scroll through pages in current window. Page indicator shows current page of pages in total.
8	Test functions	The test functions can be used during product setup to find the optimal test parameters for a specific product. See <i>"Product setup" on page 30</i> for details.

Parameters

Setting up of products and various device settings involves the following parameter types:



- | | |
|------------------------------------|---|
| <p>1 Alphanumeric</p> | <p>E.g. product- and user names.
Tap item to open an alphanumeric keyboard to edit/enter text.
See <i>"Typing" on page 27</i> for details.</p> |
| <p>2 Predefined options</p> | <p>E.g. selection of menu language or pressure unit.
Tap item to show list of predefined options.
Option lists where only one option can be selected uses radio buttons (● ○) whereas lists where you can select one or more options at the same time uses check boxes (☑ ☐).</p> |
| <p>3 Numeric</p> | <p>E.g. PIN-codes or pressure- and time settings.
Parameter value is numeric and in most cases they can only be set within a predetermined range.
Tap item to open a numeric keyboard to edit/enter value.</p> |
| <p>4 With check box</p> | <p>Tap item to enable/disable function (Check/Uncheck)</p> |

Typing

An onscreen keyboard appears automatically anytime you need to type. An alphanumeric keyboard appears when you must enter text, such as product- or user names while a numeric keyboard appears when typing numerical values only, such as PIN-codes.



In the alphanumeric keyboard you can switch between upper- and lowercase characters, special characters, numbers or symbols, by tapping the appropriate keyboard selection key to the left of the key.

The key deletes all the text whereas the key deletes the character to left of the cursor.

The and keys move the cursor one character to the left or right respectively, and the and keys make the cursor jump to the beginning or end of the text respectively.

Tapping the key confirms the input and closes the keyboard, while tapping the key will discard the entered text and exit the keyboard.

Entering accented letters or other alternate characters is done by touching and holding the related key...



...and then selecting the appropriate character from the pop-up list.

Pressing the icon will close the pop-up list without typing any character.

Bar-code scanner

If a bar-code scanner is connected to the device, it can be used to scan bar-codes for product and user creation.

The scanner can also be used to scan predefined text strings converted to bar-codes, e.g. for custom field inputs or invalid measurement notes.



Subsequently, the scanner can be used to easily and quickly select or change products or users.

See "[Select product using a bar-code scanner](#)" on page 49 for details.

Printer

If a printer is connected to the device, it is possible to print a number of copies of all measurement results.

See "[Printer](#)" on page 91 for details about compatible printers.



Get started

When you start the device for the first time and before you start making measurements, it is recommended that you perform some basic device settings.



NOTE! To be able to change device settings you must change the device to "Administrator" access level.

To do so select "Access" from the "Main Menu" - see *"Access" on page 65* for details.

- **Device Settings**

Go through the parameters available in the  **Settings** menu and make appropriate settings - see *"Settings" on page 79* for details.

- **Set up Users**

From the factory no default users have been created, but we highly recommend that you create specific users, so that you can separate measurements performed by different users later on for use in statistics etc. - see *"Access" on page 65* and *"Login" on page 84* for details.

- **Set up Products and Workflows**

From the factory no default products have been created, but we highly recommend that you create specific products, so that you can separate the different measurements later on for use in product statistics etc. - see *"Product setup" on page 30*, *"Products" on page 56* for details.

Product setup

Before you start testing a specific product in the device, it is important that the various test parameters are adapted to the specific product so that the best possible measurement results are obtained.

For the product setup we recommend that you

- use packages taken directly from the packing line to ensure proper package size, type and gas content.
- use packages without leaks.
- use plenty of test packages to achieve as consistent results as possible.

Setting up products for "Single Package" testing

(Models with PackFix only)

The setup procedure for **Single Package** products includes the following:

- Create product - see *"New" on page 58*.
- Package height adjustment.
- Determination of vacuum setting.
- Determination of leak correction factor.

Height adjustment

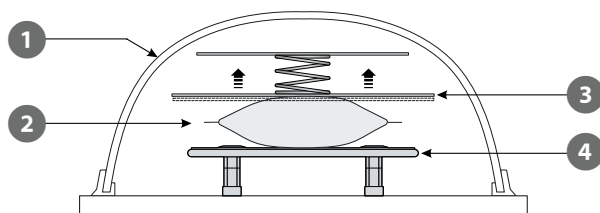

Place the package ① in the middle of the base plate and close the chamber ②. When the chamber is closed, the package should touch the PackFix ③ and preferably compress it slightly.

If it does not, use a PackBase ④ with the appropriate height to elevate the package - see *"Adjusting the height of the PackBase" on page 38* for details.



NOTE! Different packages have different height adjustment requirements. A large flexible package can have a span of 15mm, while a hard tray with a top foil might only have few mm flexibility.

If you have several different package types (with different heights) it might be a good idea to have several PackBases, each one adjusted for the specific package type.

Determination of vacuum setting

The below procedure requires that the necessary height adjustment has been performed as described in "*Height adjustment*" on page 30 and that the package is positioned accordingly.

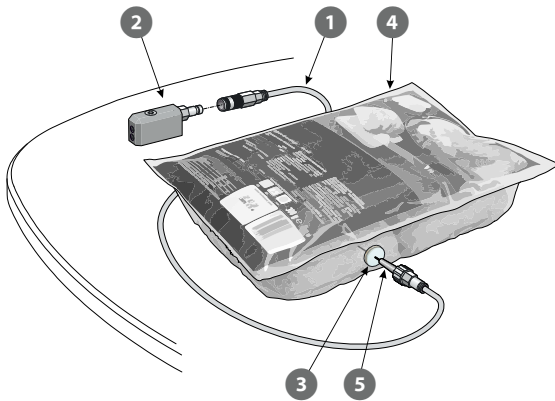

1. Connect the Delta P measuring hose 1 to the quick connector 2 in the chamber. Place a septum 3 on the package 4 and push the needle 5 through it.



NOTE! Make sure that neither the needle nor the hose is hit by the PackFix and the chamber when the chamber is closed. We recommend to place the needle through the side of the package.



CAUTION! Make sure that the needle does not touch the product in the package, as this could clog or soil the needle and/or hose. If this happens, the needle and/or hose must be cleaned or replaced to avoid destroying sensors or other items inside the device.

2. Select **Workflow** -> **Products** -> **Edit** and then select the product you have created for the specific package type.
3. Set **Mode** to **Single Package**.
4. Tap the yellow icon to go to the **Create Test Vacuum** screen.

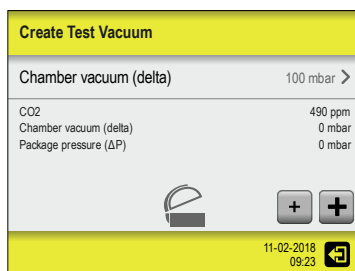

5. Set the **Chamber vacuum (delta)** to **100 mbar**, then close the chamber to start the measurement.

6. The chamber will be evacuated to the set value and the measured values are continuously displayed on the screen.

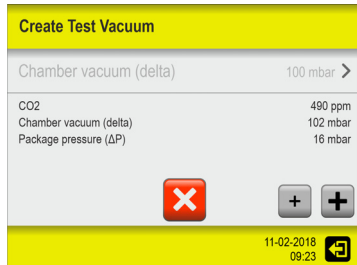

NOTE! If the currently measured “CO2” value increases when vacuum is applied, then the package is most likely leaking and you should thus use another package to perform the test.

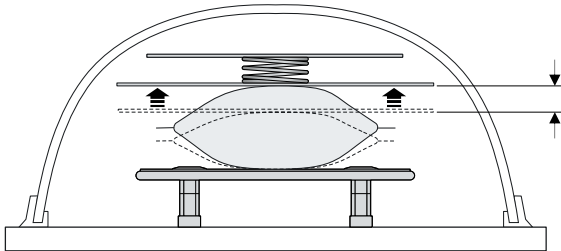

During the measurement, check how much the package compresses the PackFix. For larger, very flexible packages the optimal measurement is obtained when the PackFix is compressed approx. 10-15 mm, which is approx. half of its total range of motion. For smaller, less flexible packages the movement may be heavily reduced. A smaller package will most likely need a higher setting of the **Chamber vacuum (delta)** than a large package to properly compress the PackFix.



NOTE! Be aware that a higher “Chamber vacuum (delta)” setting does not necessarily result in better measurements. This can cause PackFix to be completely compressed, whereby the Delta P pressure becomes very unstable from package to package and it will therefore not be possible to determine the correct hole size.

7. If necessary use the and buttons to increase the chamber pressure by 10 or 50 mbar respectively until the optimal PackFix compression is obtained, then press the button to stop the test.

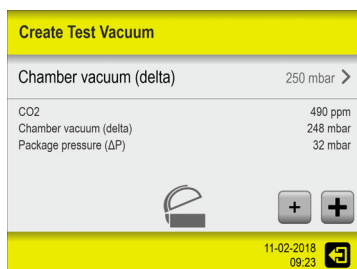



NOTE! A Package pressure (ΔP) value of 25 mbar or higher is a good indicator that the device can measure leaks in the package. Values between 15 and 25 mbar will work on some types of packages, whereas values below 15 mbar can be critical.

On packages with a CO₂ content below 25%, a ΔP of 25 mbar can be too low. On packages with a very high content of CO₂ leaks might be detected at ΔP values below 15 mbar.

If a package's content of CO₂ as well as the achievable ΔP makes it difficult to obtain uniform measurement results, you may also consider trying with a longer or shorter test time than the default set test time.

See "**Test Time** *" on page 59 for details.

8. Tap the  icon to exit and return to the product settings. The final **Chamber vacuum (delta)** and **Package pressure (ΔP)** values are added to the **Error/Event Log**.
9. Now set **Vacuum Delta** to the value as obtained above.

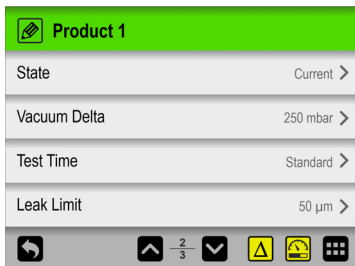

10. Tap the yellow  icon to open the test measurement function.....



...then close the chamber to start the measurement.

11. During the measurement, check that the PackFix is properly compressed.
12. When the test is completed...



...verify that the measured ΔP is very close to the values as obtained earlier.

13. Tap the  icon to exit and return to the product settings.

Determination of the Leak Correction Factor

To ensure that measurements are as uniform and correct as possible, the leak correction factor should be adjusted individually for each product.

This is done by testing the packages with a known hole size, and therefore the testing should be performed using the leak simulation kit, that comes with the device.

This kit corresponds to a **Standard 100 µm Dansensor hole**.

If you want to make similar measurements with other hole sizes, we recommend using our **Leak Simulation Kit**, which is an accessory that must be ordered separately - see "[Options/Accessories](#)" on page 91 for details.

The procedure requires that the necessary height adjustment and determination of vacuum setting has been performed as described in "[Height adjustment](#)" on page 30 and "[Determination of vacuum setting](#)" on page 31 and that the package is positioned accordingly.

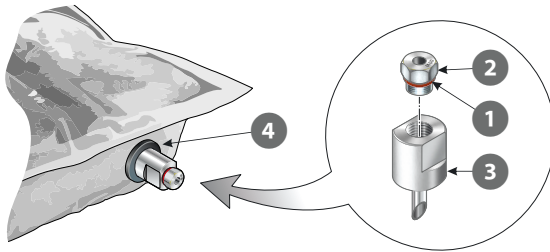

1. Place the O-ring ① on the restrictor ②, then assemble it with the needle ③.
2. Place a septum ④ on the package.
3. Press the needle through the hole in the septum and into the package making sure that the needle is fully seated onto the septum.
The needle should be inserted just before the test is done to ensure that the gas concentration and gas amount in the package is correct.



NOTE! Make sure that the needle is not hit by the PackFix and the chamber, when the chamber is closed. We recommend to place the needle through the side of the package.



CAUTION! Make sure that the needle does not touch the product in the package, as this could clog or soil the restrictor.

4. Select **Workflow** -> **Products** -> **Edit** and then select the product you have created for the specific package type.
5. Check that the **Leak Correction Factor** is **1.00** (default for all new products)...

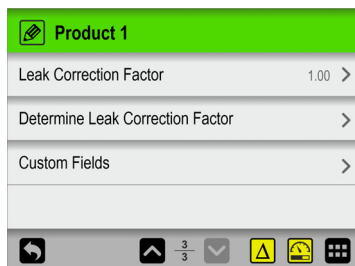

...then press **Determine Leak Correction Factor**.

6. In the appearing window...

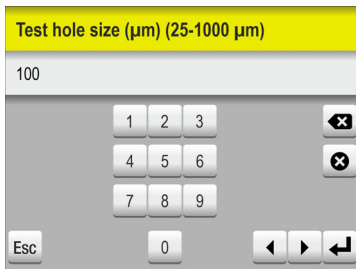

...enter **100** as the current test hole size and press **↵** key.

7. As you can see in the appearing **Leak Correction Factor** window, it takes 5 measurements to calculate a valid correction factor.

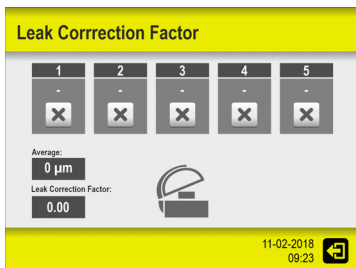

8. Close the chamber to start the measurement.

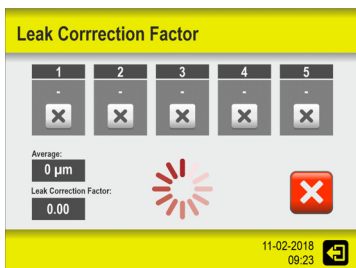

9. When the test is completed, the result is displayed in the corresponding field, an **Average** value is calculated and the value in the **Leak gain factor** field is updated accordingly.

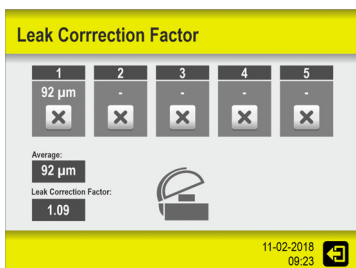

10. Prepare a new package as described earlier, place it in the chamber and start the next measurement.

11. If you find that a measurement for some reason deviates so much that it cannot be considered as valid (f.ex. caused by a clogged needle or an odd package)...

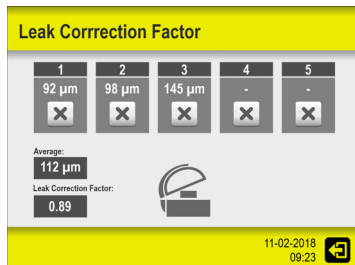

...you can delete it by pressing the button below the measurement result. And if you want to quit the function, you can tap the icon in the lower right corner...

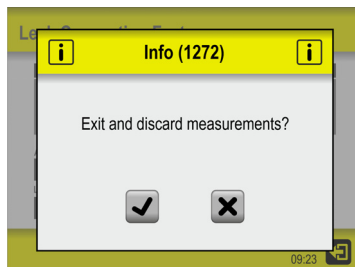

...and then press the button to return to the product settings.

12. Otherwise perform the above procedure using a new package each time, until you have 5 valid measurements.

NOTE! Using the same package several times may lead to decreasing delta pressure which will result in smaller and smaller hole size measurements, especially for small packages.

13. Based on the 5 measurements, a final **Average** value is now calculated and thus also a corrected **Leak Correction Factor**.

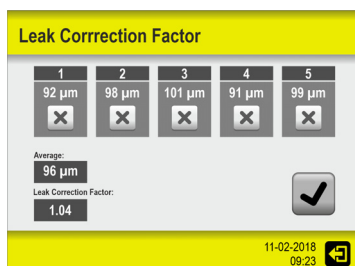

Press the button to acknowledge the results...

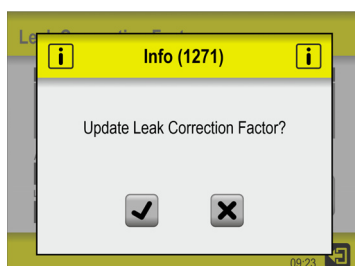

...and then press the button to update the **Leak Correction Factor**.

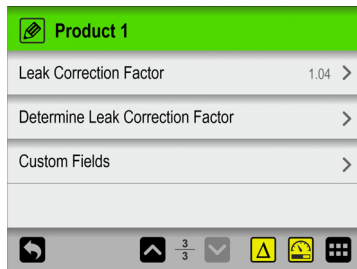

The final **Test hole size, Average,** and **Leak Correction Factor** values are added to the **Error/Event Log**.

14. When **Leak Correction Factor** has been updated, prepare one more package and make a control measurement using the test measurement function  to confirm that the measured hole size is approx. 100 µm (provided the delta pressure is OK).
15. Save the product.

Adjusting the height of the PackBase

The PackBase consists of a wire mesh and 4 adjustable feet. It comes with a selection of parts that allow for different height adjustments. Adjustment ranges are 15.5 to 76.5 mm for **LeakPointer 3** and 15.5 to 116.5 mm for **LeakPointer 3+**.

Fit a leg **2** in each corner of the wire mesh **1** using the parts necessary for the required height - see *Fig. 1. PackBase height overview on page 39* for details.

Since the legs should not be tightened much when assembling, it does not require for the use of any tools. Simply press down on the screw **3** while tightening the parts by hand.

If you need to use the spacer **4** with the threaded insert **5**, first take out the insert and fit it loosely on the screw, then push the spacer **4** onto it and use it to tighten the insert while making sure that the small buds on the spacer **4** fits the holes in the counterpart **6** when pushing the items together.

i **NOTE!** Especially for the LeakPointer 3+ PackBase it may be necessary to move the legs slightly towards the centre of the wire mesh if the grid is pressed too much downwards when pressure is applied.

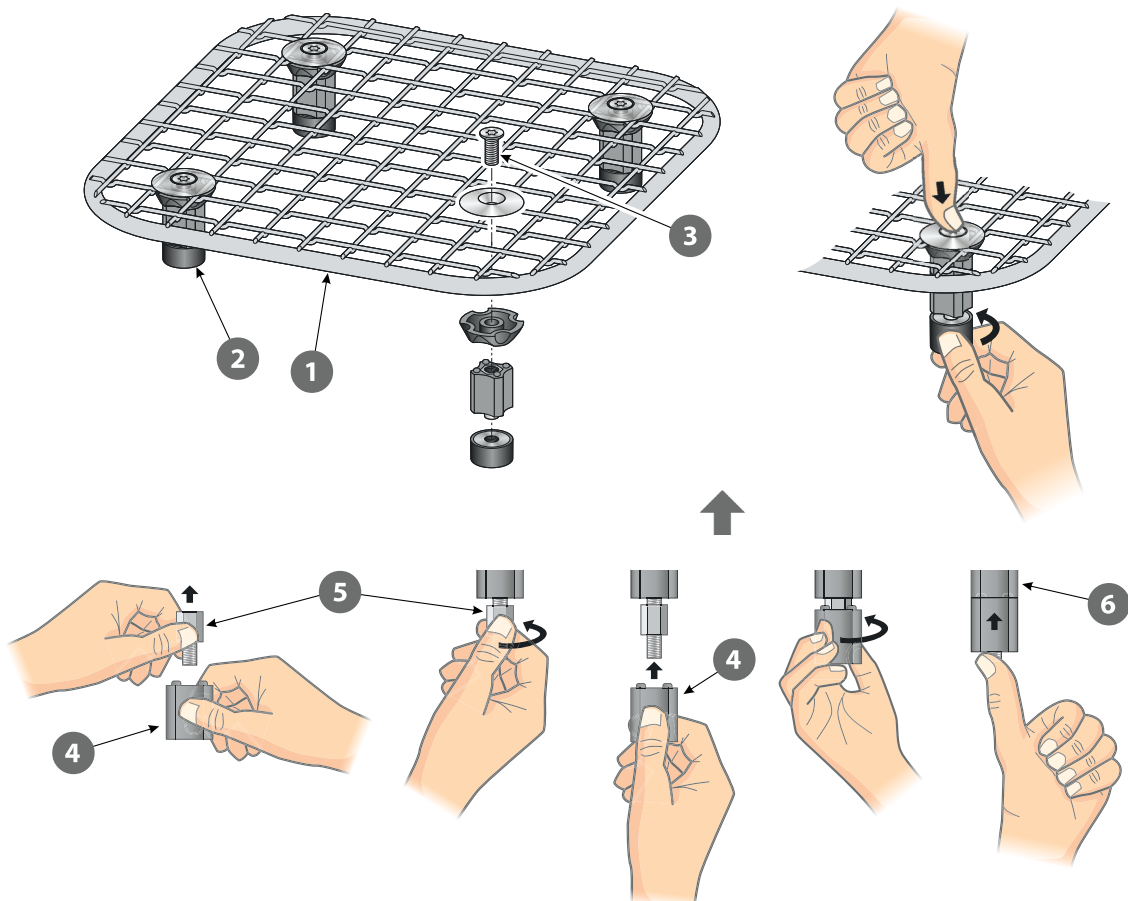

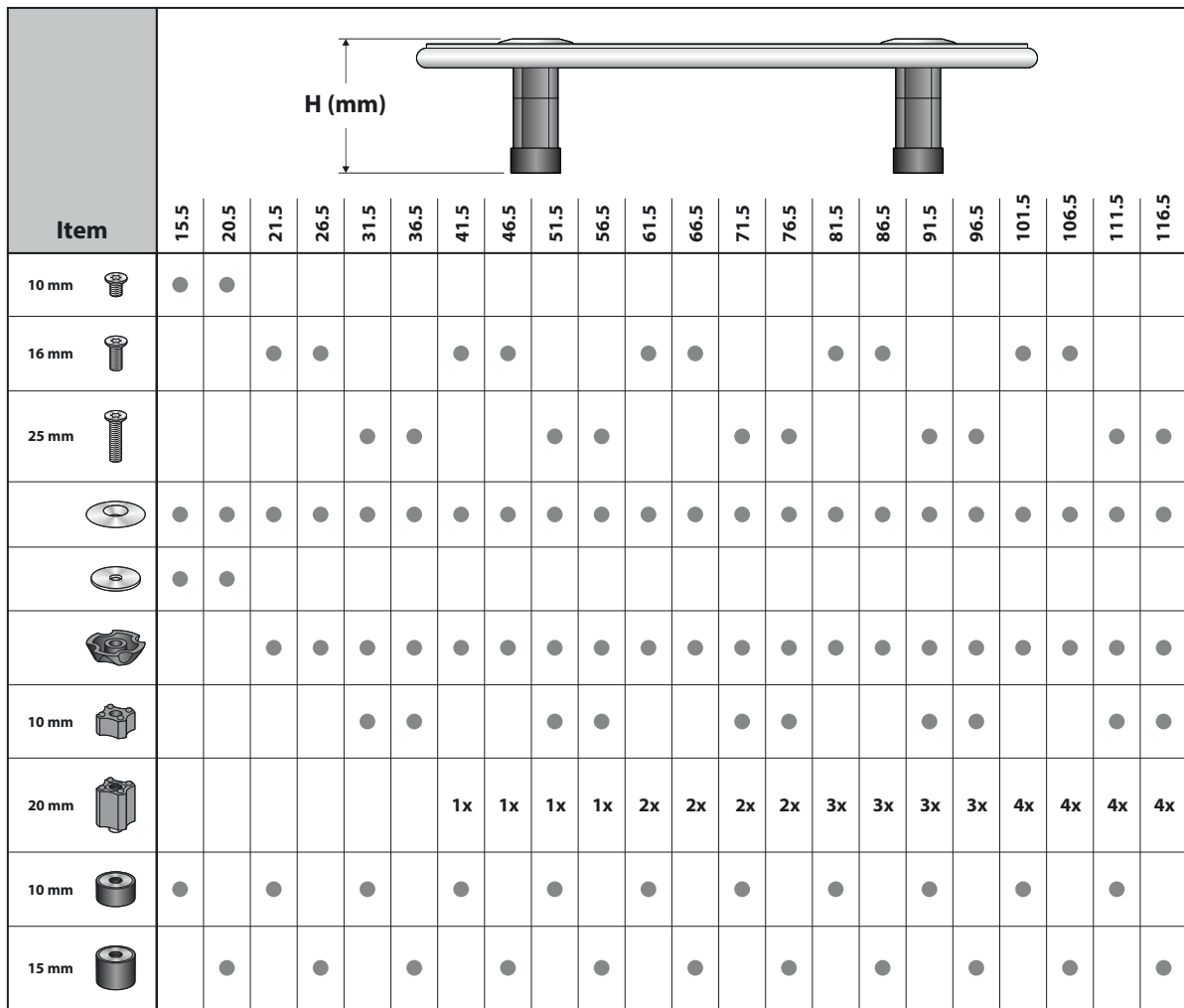











Item	H (mm)																						
	15.5	20.5	21.5	26.5	31.5	36.5	41.5	46.5	51.5	56.5	61.5	66.5	71.5	76.5	81.5	86.5	91.5	96.5	101.5	106.5	111.5	116.5	
10 mm 	●	●																					
16 mm 			●	●			●	●			●	●			●	●			●	●			
25 mm 					●	●			●	●			●	●			●	●				●	●
	●	●	●	●	●	●	●	●	●	●	●	●	●	●	●	●	●	●	●	●	●	●	●
	●	●																					
			●	●	●	●	●	●	●	●	●	●	●	●	●	●	●	●	●	●	●	●	●
10 mm 					●	●			●	●			●	●			●	●				●	●
20 mm 							1x	1x	1x	1x	2x	2x	2x	2x	3x	3x	3x	3x	4x	4x	4x	4x	
10 mm 	●		●		●		●		●		●		●		●		●		●		●		
15 mm 		●		●		●		●		●		●		●		●		●		●		●	

Fig. 1. PackBase height overview

Removing the PackFix

If for some reason the PackFix prevents you from testing a particular type of package, it may be temporarily removed from the device as described below:

1. Use a Torx 20 screwdriver to loosen the screws **1**.
2. Now turn the PackFix slightly counter-clockwise so that the screw heads can pass through the keyholes **3** on the PackFix base plate and the PackFix can then be removed.
3. Finally either tighten the screws **1** or alternatively remove both screws **1** and washers **2** completely.
4. For installing the PackFix again, see *"Installing the PackFix" on page 41*.

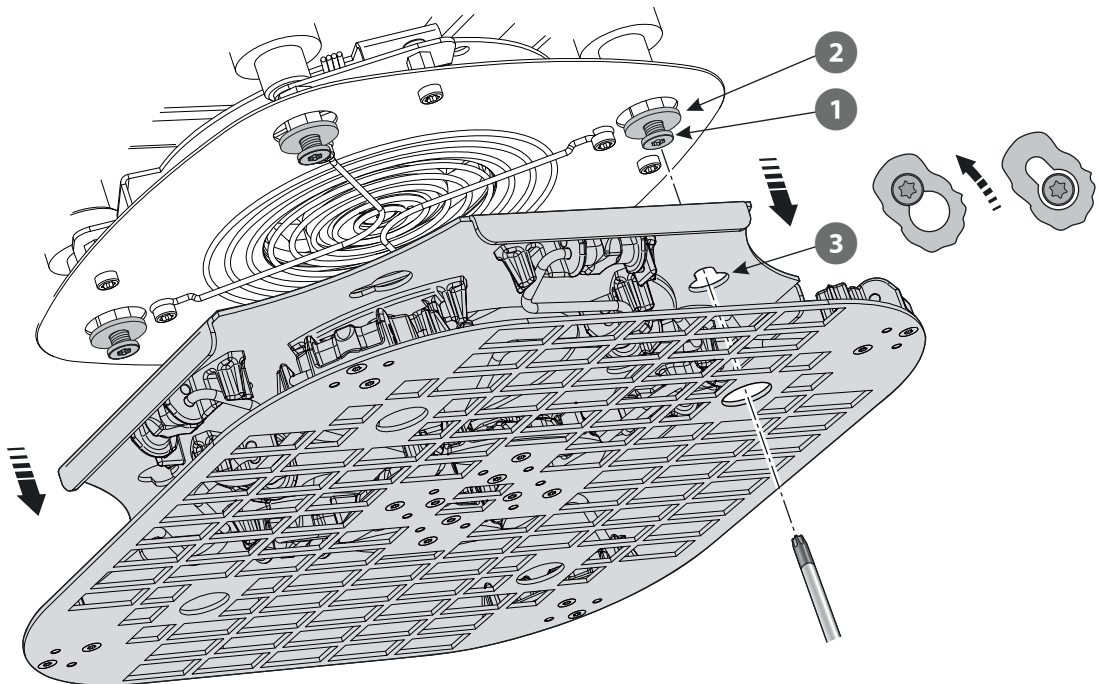

Installing the PackFix

If for some reason the PackFix has been removed from the device, it can be installed again as described below:

1. If screws **1** and washers **2** have been removed earlier, use a Torx 20 screwdriver to mount them in the hexagonal stays **5** again.
Do **NOT** tighten the screws but leave a gap of 2 - 3 mm (see detail).
2. If screws **1** and washers **2** are already there, use a Torx 20 screwdriver to loosen the screws to a gap of 2 - 3 mm (see detail).
3. Install the PackFix by passing the screw heads through the keyholes **3** in the PackFix base plate and then turn the PackFix slightly clockwise as far as it goes (see detail).
4. Tighten the screws through the corresponding holes **4** in the grid plate.

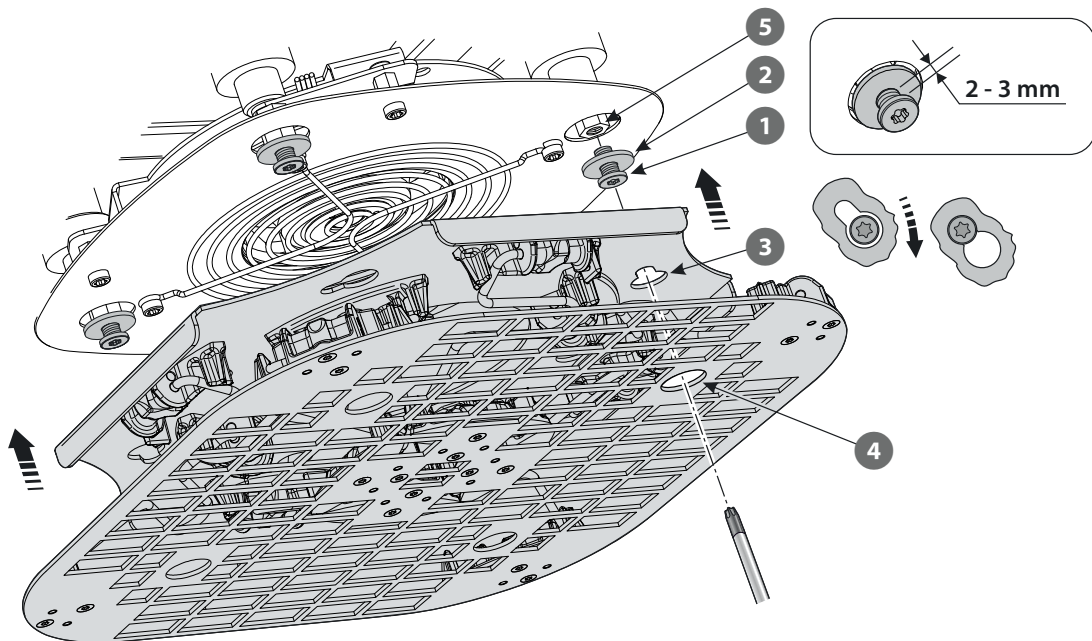

Adjusting the PackFix pressure

From the factory the PackFix is delivered in a 100N version for a **LeakPointer 3** and a 200N version for a **LeakPointer 3+**.

If for some reason it is considered that the standard PackFix is too hard to achieve the desired compression and thereby an appropriate delta pressure in the package, it is possible to convert it to a lighter compression pressure by removing a number of springs:

1. Remove the PackFix as described in *"Removing the PackFix" on page 40*.
2. Use a Torx 10 screwdriver to remove the screws ① and then remove the base plate ②.



NOTE! To remove springs ③ from the bearings ④, it will be necessary to lift the upper bearing upwards so that you can pull the spring out of the holes in the bearings.

Also when fitting springs in the bearings, always fit the short part (A) of the spring in the upper bearing holes (C) and the long part (B) in the lower holes (D) as illustrated.

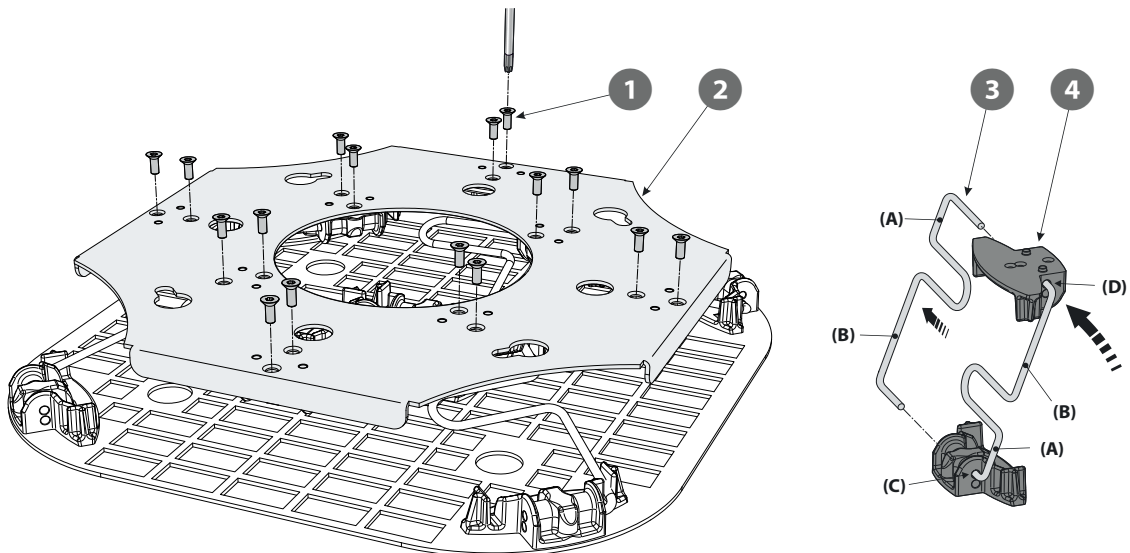

3. Remove the required number of springs to obtain the appropriate pressure- see *Fig. 2. PackFix configurations on page 43* for details.

i **NOTE!** To avoid twisting of the PackFix during compression, it is important that the springs are positioned exactly as shown in Fig. 2. Even though the drawing shows it, it is not necessary to remove the bearings on the LeakPointer 3 PackFix when removing the springs. Keeping the bearings in place makes it easier if springs need to be fitted again.

LeakPointer 3:**LeakPointer 3+:**

Fig. 2. PackFix configurations

4. Assemble the PackFix again and install it as described in *"Installing the PackFix" on page 41*.

Setting up products for “Multi Package” testing

The setup procedure for **Multi Package** products includes the following:

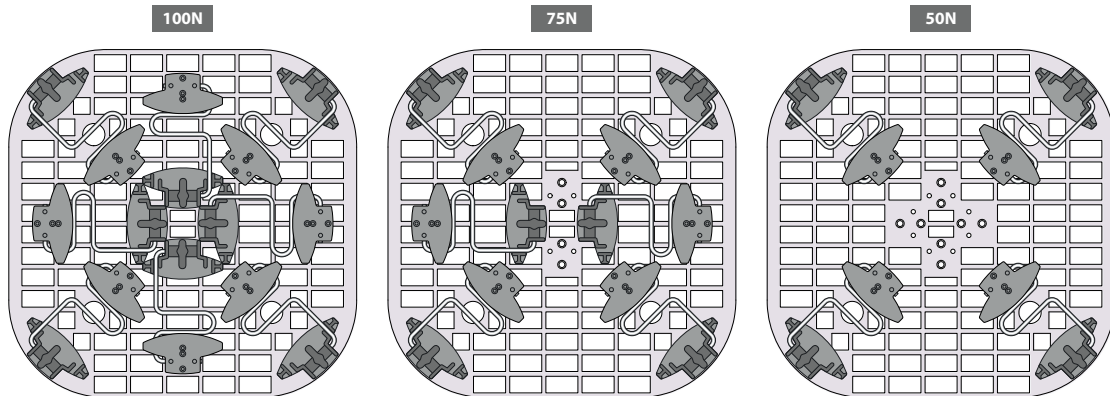
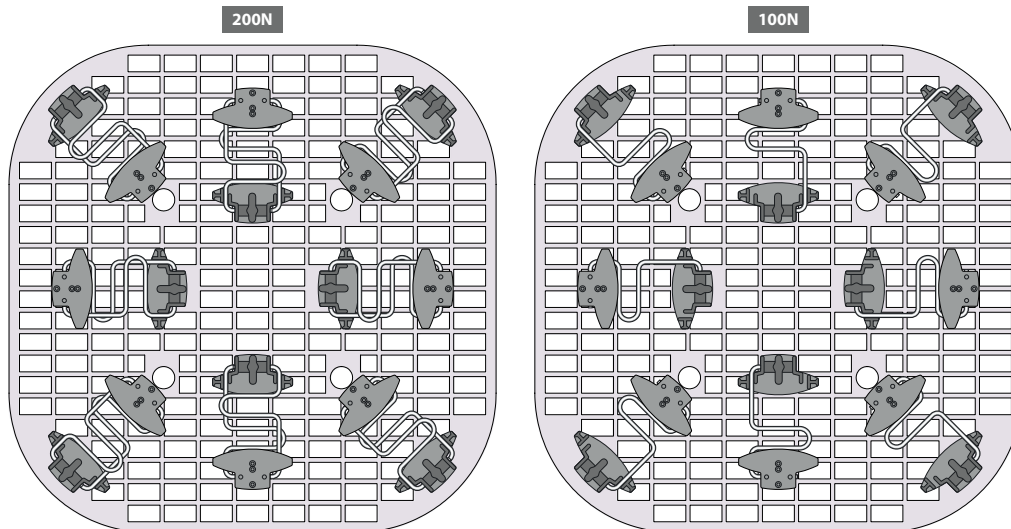
- Create product - see *"New" on page 58.*
 - Determination of vacuum setting
1. Prepare the test package for DeltaP measuring as described in *"Determination of vacuum setting" on page 31.*



NOTE! Make sure that neither the needle nor the hose is hit by the chamber when the chamber is closed. We recommend to place the needle through the side of the package.

2. Select **Workflow** -> **Products** -> **Edit** and then select the product you have created for the specific package type.
3. Set **Mode** to **Multi Package**.
4. Tap the yellow icon to go to the **Create Test Vacuum** screen.

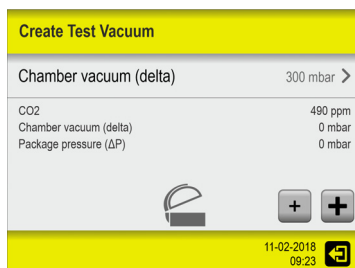

5. Set the **Chamber vacuum (delta)** to **300 mbar**, then close the chamber to start the measurement.
6. The chamber will be evacuated to the set value and the measured values are continuously displayed on the screen.

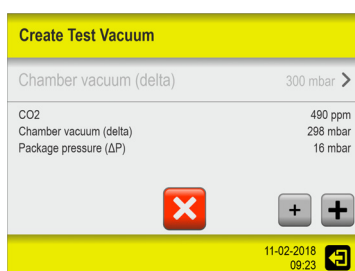

NOTE! If the currently measured “CO2” value increases when vacuum is applied, then the package is most likely leaking and you should thus use another package to perform the test.

7. During the measurement, observe the **Package pressure (ΔP)** value.



NOTE! A Package pressure (ΔP) value of 25 mbar or higher is a good indicator that the device can measure leaks in the package. Values between 15 and 25 mbar will work on some types of packages, whereas values below 15 mbar can be critical.

On packages with a CO₂ content below 25%, a ΔP of 25 mbar can be too low. On packages with a very high content of CO₂ leaks might be detected at ΔP values below 15 mbar.

If a package's content of CO₂ as well as the achievable ΔP makes it difficult to obtain uniform measurement results, you may also consider trying with a longer or shorter test time than the default set test time.

See **"Test Time *"** on page 59 for details.

If necessary use the and buttons to increase the chamber pressure by 10 or 50 mbar respectively until you have obtained an appropriate ΔP value as described above, then press the button to stop the test.



NOTE! The selected vacuum level needs to be high enough to ensure an appropriate " ΔP " value, but not so high that it damages the package.

8. Now write down the final **Chamber vacuum (delta)** value and the obtained **Package pressure (ΔP)** value.

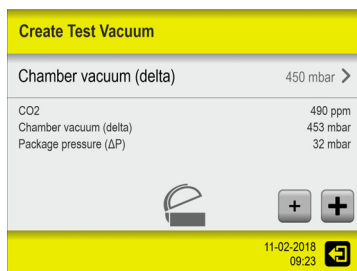

9. Tap the icon to exit and return to the product settings.

10. Now set **Vacuum Delta** to the value as obtained above.

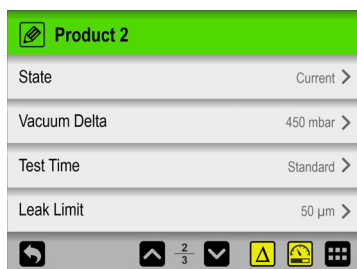

11. Tap the yellow  icon to open the test measurement function....



...then close the chamber to start the measurement.

12. When the test is completed...



...verify that the measured ΔP is very close to the values as obtained earlier.

13. Tap the  icon to exit and return to the product settings.

Measuring

CO₂ levels

High or unstable background CO₂ levels can affect the function of the device as well as the measurements made in the device.

The device responds as follows in the situations described below:

- If the CO₂ level in the chamber exceeds a certain value (default = 7500 ppm) before a measurement is started or if the CO₂ value in the chamber exceeds a certain value (default = 9500 ppm) during a current measurement, the process is interrupted and the following error message appears:

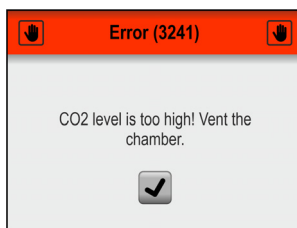

In these cases, it is recommended to open the chamber and wait approx. 30 sec. before trying again.





In some cases it may even be necessary to ventilate the room where the device is located, at the same time.

- If the increase in the CO₂ level in the chamber exceeds a certain value (default = 5000 ppm) during a current measurement, the process is interrupted and on the measurement screen the result is indicated as a "LEAK" of either 999 µm or 99.9 ppm/s depending on the selected measurement method.

Selecting a product for measuring



1. In the measuring screen....



... tap the  icon in the top left corner. This will bring up the  **Select Product** screen. (This screen can also be reached by tapping the  icon in the bottom right corner, and then selecting  **Products** ->  **Select (as active)**).



The  **Select Product** screen lists all products in last used order with the currently selected product at the top (in orange).

- Use  and  keys to scroll through the list to find the appropriate product.



NOTE! If you have a large number of products, scrolling through the list may be quite time consuming. In this case you can use the “Find” and “Filter” functions - see ***“Find and Filter” on page 61*** for details.

- Once you have found the required product, tap it to select it and return to the measuring screen.



Select product using a bar-code scanner

1. The device must be ready and show the measuring screen.



2. Use the bar-code scanner to scan the product's bar-code



3. If the bar-code matches the **Product ID** of a valid product, this product will now be selected as the active product.



Performing a workflow/measurement

For Single Package testing with PackFix:

Place the test package ① in the center of the base plate ②.

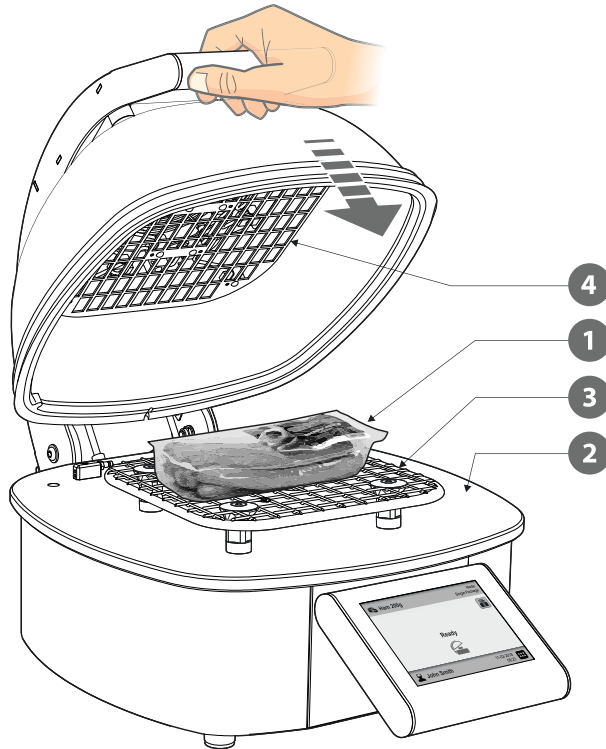

If the current measurement requires the use of a PackBase ③, this is placed in the middle of the base plate, after which the package is placed in the middle and on top of it.



NOTE! It is important that the package is placed in the middle of the chamber, as this ensures a stable and uniform pressure on the PackFix mechanism ④.

For package testing without PackFix:

Place the test package ① in the center of the base plate ②.

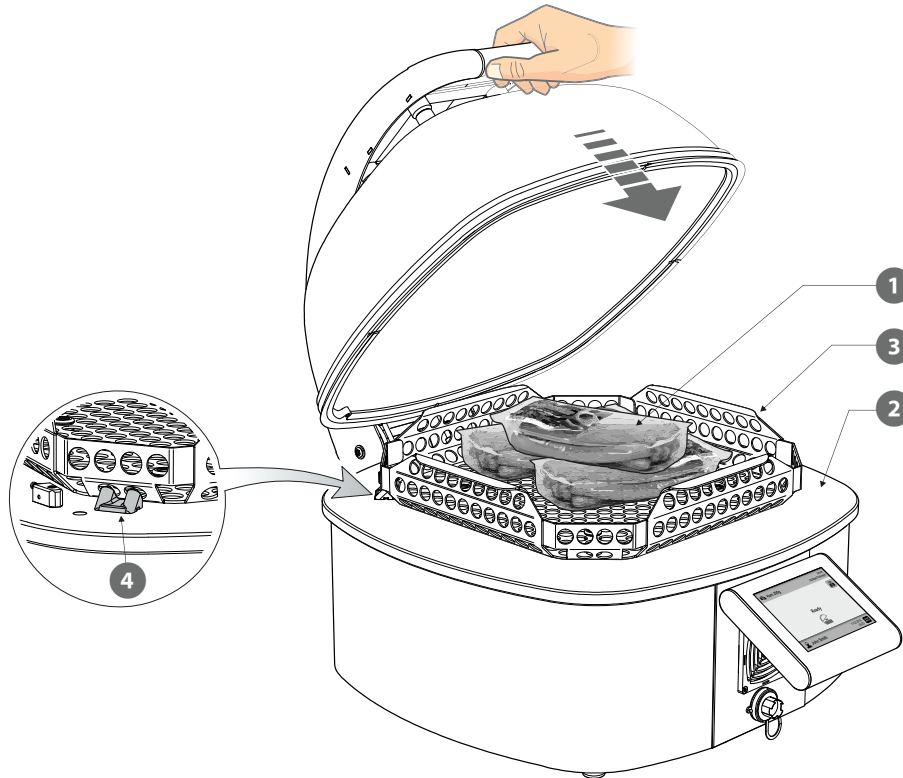



If testing multiple packages using a PackTray ③, place the PackTray's corners up against the stop blocks ④ in the rear corners of the base plate ② (see detail).

Performing measurement:

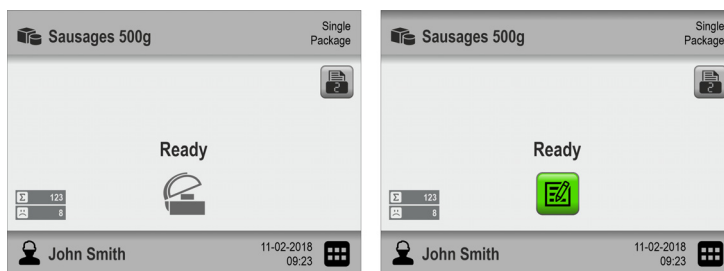
1. Select appropriate product - see *"Selecting a product for measuring" on page 47*.
2. When the device is ready, the display will show one of the screens below.



3. The  button appears if the selected product requires entering of data in one or more predefined custom fields before measuring starts. If this is the case, proceed from item 4, otherwise go to item 7.
4. Press  button to start the workflow.

5. If the first custom field requires entering of, for example, **Batch no.**, a keyboard will appear.

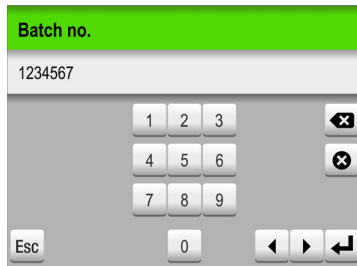

Enter appropriate information and press key.

6. If another custom field is required, this could, for example, be selection between 2 predefined options, e.g. packaging machines.

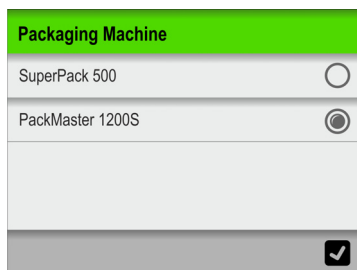

Make your selection and press .

7. When display changes to...



... close the chamber and keep it closed, until an appropriate vacuum has been established inside the chamber.

Please note that if an extended stabilisation time has been set (**Settings** -> **Device** -> **Extend stabilisation time**) this time starts now and only when it expires and the measurement symbol starts to rotate....



...you can let go of the chamber, and the measurement is being performed. The test can be aborted anytime by pressing the button.

- When the measurement is complete, the result is displayed on the screen.



Results for **Single Package** mode measurements are read out as the calculated hole size in μm , while **Multi Package** mode results are read out as the measured increase in the CO_2 level in the chamber in **ppm/s**.

The 😊 symbol means that the measurement is within the allowed range, while the 😞 symbol means that the measurement is higher than the allowed range.

The small statistics counter in the lower left corner of the display will be updated accordingly.

- If **Acknowledge Measurement** is enabled in **Main Menu** -> **Workflow** you must press the 😊, 😞, or 🗨️ button now to validate and end the measurement/workflow - see [page 23](#) for details.
- The device is now ready for a new measurement/workflow.

Cleaning

General

Performing cleaning and maintenance regularly reduces the chances of equipment failure.



CAUTION! Personnel performing any maintenance or cleaning must familiarize themselves with the information in **"Safety and handling instructions" on page 93** before attempting any of these procedures.



CAUTION! Never use mineral oil, steam or boiling water on or near the chamber.

See **"Consumable parts and options" on page 91** for details about consumables and replacement parts.

Cleaning

- Use the ON/OFF button on the back of the device to switch the device off.
- For normal cleaning use a soft, lint-free cloth with a mild soap solution. Avoid getting moisture in openings.
- Use alcohol to remove any chamber sealing residue from the base plate **1**.
- The fan in the top of the chamber should be cleaned as often as necessary depending on the environment, but we recommend to clean it at least once every month. Use e.g. an air pressure gun **2** to gently blow air through the fan.



CAUTION! Blowing the air gun directly at the fan can cause it to run very fast. This can potentially damage the fan.



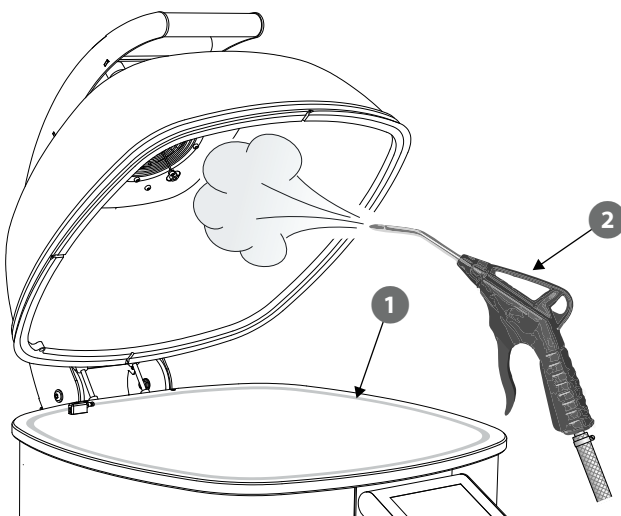

NOTE! When using compressed air for cleaning, make sure that air is dry and oil free.







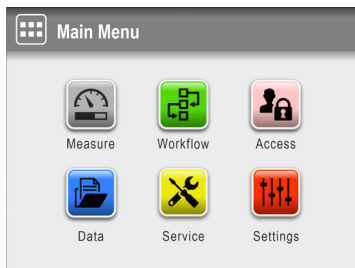

4. Menus and Settings

Main menu

Tapping the  icon in the lower right corner of the measuring screen takes you to the  **Main Menu**.



Please note that the access level of the current user determines which features and menus are available - see *"Access levels" on page 66* for details about the various access levels and the associated rights.

 Measure	Takes you to the measuring screen. See <i>"Performing a workflow/measurement" on page 50</i> for details.
 Workflow	Definition of workflows and set-up of products. See <i>"Workflow" on page 56</i> for details.
 Access	Selection and administration of user access levels. See <i>"Access" on page 65</i> for details.
 Data	View logged data for a product. See <i>"Data" on page 70</i> for details.
 Service	Perform test measurements and view device serial nos., SW version and counters etc. See <i>"Service" on page 74</i> for details.
 Settings	Setting of various device parameters. See <i>"Settings" on page 79</i> for details.

IMPORTANT!

When changes are made to device settings, workflows and users etc., most of these are not saved until you return to the previous menu level.

To make sure changes are saved, you should go to the main menu and wait at least 30 sec. before switching the device off.



Workflow

A workflow is set up as a combination of a product, the actual measurement and a number of predefined custom fields. During the workflow the custom fields allow the user to enter optional texts or numbers and/or to select from a list of predefined text strings. All data entries are saved together with the measurement result in **Collected Data** in the **Data** menu - see *"Data" on page 70* for details.

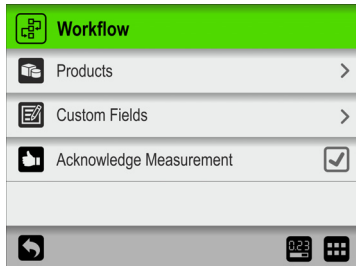

Parameters marked with an asterisk (*) are only available when logged in as "Administrator".



Products

Select, create, edit and delete products.
See *"Products"* below for details.



Custom Fields *

Setting up of the various custom fields.
See *"Custom Fields" on page 63* for details.



Acknowledge Measurement *

If enabled, a set of buttons appear on the measuring screen for validation of the measurement - see detailed description for item 11 in *"The Measuring screen" on page 22*.



Products

Selecting **Products** from the **Workflow** menu will display a menu with the available product options. The total number of products that can be created is 999.

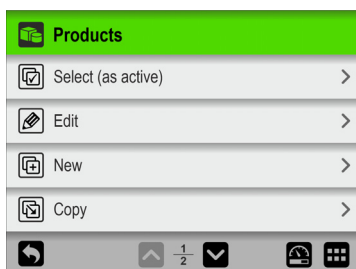



Select (as active)

Select the product, you wish to perform measurements on.
See *"Select (as active)" on page 58* for details.

 **Edit**

Edit an existing product.

Product settings are described in *"New" on page 58*.

Most of the product parameters can only be edited if no measurements have been performed using the product or if the parameter  **Settings** ->  **Device** -> **Lock Product** has been disabled.

When having edited a product, a message appears when exiting the function:



Tap  to save changes.

 **New**

Creates a new, blank product.

See *"New" on page 58* for details.



 **Copy**

Use this function to create a new product that is similar to an existing product.

Product settings are described in *"New" on page 58*.

Make required changes to the new product, and when finished, a message appears when exiting the function:



Tap  to save the new product and return to the  **Products** menu.

 **Delete**

When deleting a product both the product and the product's logged data are deleted.

The action must be confirmed before the product is deleted.

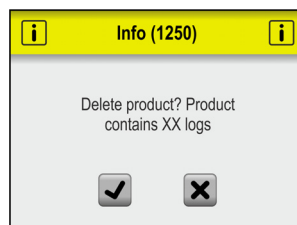



Select (as active)

This function allows you to select the product, you wish to perform measurements on.

1. Select  **Select (as active)** (or tap the  icon in the top left corner of the measuring screen).



The appearing  **Select product** screen lists all products in “last used” order with the currently selected product at the top (in orange).

2. Use  and  keys to scroll through the list to find the appropriate product, then tap it to select it and return to the measuring screen.
3. If you have a large number of products, scrolling through the list may be quite time consuming.

In this case use the  **Find** and/or  **Filter** functions which can be selected in the bottom of the screen - see "[Find and Filter](#)" on page 61 for details.

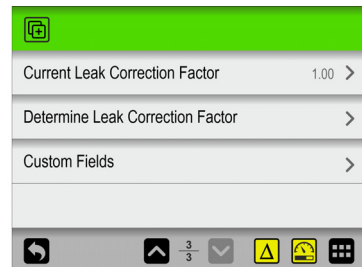
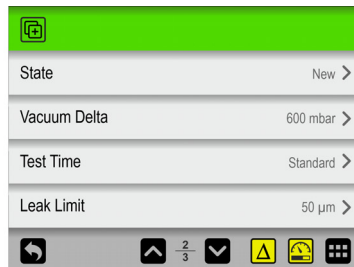
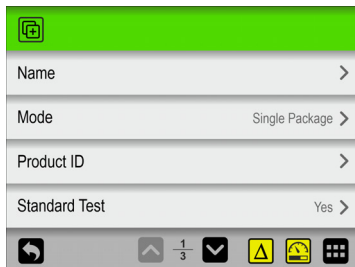

New

Creates a new product with default settings.





TIP! If a new product will be very similar to an existing product, you might want to use the “Copy” function.

The following parameters can be set for a product:

Parameters marked with an asterisk (*) can not be changed, when product has been used for a measurement and if the parameter  **Settings** ->  **Device** -> **Lock Product** has been enabled.

Name *	A unique product name (up to 30 characters).
Mode *	Select measuring mode (Single Package or Multi Package)
Product ID *	Unique product identification code (up to 20 characters).
Standard Test	If set to No , the product is not available for the Standard Test Operator . Product will still be available for an Operator and Supervisor .

<p>State</p>	<p>Only used if Use State Mark is enabled in  Settings ->  Device. Can be used by a Supervisor to categorize the various products in the product list:</p> <p>New Automatically assigned to new products. Can for example be used for products where settings are still being considered/tested.</p> <p>Current Typically used for products that have been approved for use. This category of products are the only products available to the Standard Test Operator (provided that the Standard Test option is set to Yes).</p> <p>Old Can for example be used for discontinued products or products that should not be used for a period.</p>
<p>Vacuum Delta *</p>	<p>Test pressure difference. The value indicates the vacuum that the test objects will be tested under in relation to atmospheric pressure. The higher the figure, the deeper the vacuum. See "<i>Product setup</i>" on page 30 for a detailed description of the procedure of determining the optimal setting for specific products.</p>
<p>Test Time *</p>	<p>Test time. The test time should be adapted to the specific package characteristics in terms of size, headspace amount, CO₂ content, achievable DeltaP etc.</p> <p>Standard (Default setting)</p> <p>Short Applies to small packages with limited headspace, packages with large leaks, packages with a high CO₂ content and/or high DeltaP capability.</p> <p>Long Applies to large packages with a large amount of headspace and low CO₂ content and/or low DeltaP capabilities.</p>
<p>Leak Limit *</p>	<p>Product leak limit. A package will be rejected if the measured leak value exceeds this value.</p> <p>The Mode setting determines the readout units: Measurements in Single Package mode are read out as the calculated hole size in µm, while measurements in Multi Package mode are read out as the measured increase in the CO₂ level in the chamber in ppm/s.</p>



Leak Correction Factor *	To ensure that measurements are as uniform and correct as possible, the correction factor should be adjusted individually for each product. See " <i>Product setup</i> " on page 30 for a detailed description of the procedure of determining the correct setting for specific products.
Determine Leak Correction Factor	See " <i>Product setup</i> " on page 30 for a detailed description of the procedure of determining the correct setting for specific products.
Custom Fields	Select if one or more of the 4 custom fields will be required for the current workflow - see " <i>Custom Fields</i> " on page 63 for details.

When finished, a warning appears when exiting the function:





Tap to save the new product and return to the  **Products** menu.

 **Find** and  **Filter**

The  **Find** and  **Filter** functions can be helpful if you have a large number of products thus making scrolling through the list quite time consuming.

The functions can be used separately, or combined as described below:

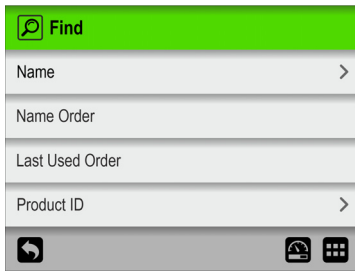

1. Tap the  icon to bring up the  **Find** screen.





2. Select the appropriate search method. Selecting either the **Name** or **Product ID** methods brings up a touch screen keyboard for keying in the search text.

 **NOTE!** The “Name” or “Product ID” search methods will not find all products, with the search text appearing somewhere in the name or product ID, but only products where the name or product ID starts with the entered search text.



3. Key in the product name (e.g. **Ham**) and confirm by tapping the  key.
4. The  **Select Product** screen will appear showing a list of found products with names starting with **Ham**.



5. Now tap the  icon to bring up the  **Filter** screen.

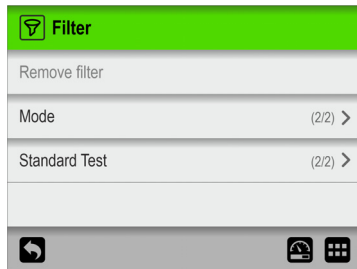

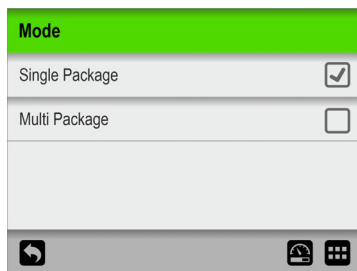

6. Select the required filtering parameter, e.g. **Mode**.

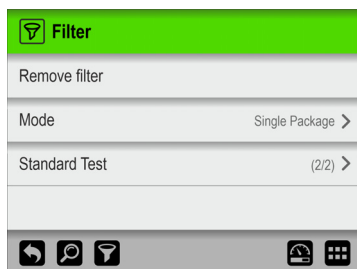

Make required setting, then press the  key.

7. Now you can see the selected **Mode** filter setting.



Select another filtering parameter or press the  key to return to the list of products that meet the search- and filter criteria.

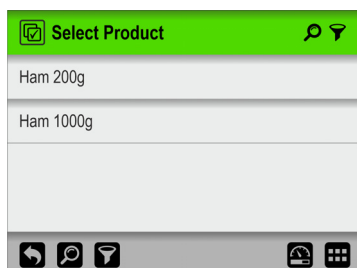

8. Tap the appropriate product to select it and return to the measuring screen.

Custom Fields

Use the custom fields to add various information about a specific measurement during a measurement workflow. The data entries are saved together with the measurement result.

4 custom fields are available, each of which can be individually defined with a name and an input type. Whether or not a field entry is required, is set up for each product individually.

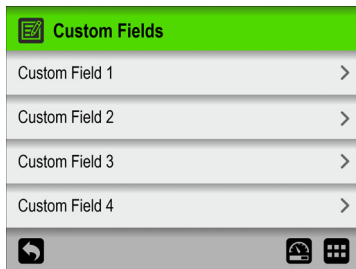

Custom Field settings

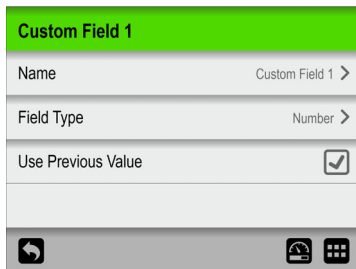

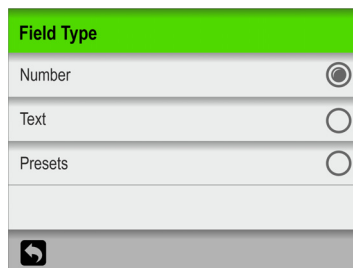

Name A unique custom field name (up to 32 characters).

Field Type Select the type of required input:



When type is set to either **Text** or **Number**, the appropriate type of keyboard appears when an entry is required.

When type is set to **Presets** you have the possibility to define up to 4 different text fields.

Field Type		Presets	
Number	<input type="radio"/>	Preset Text 1	>
Text	<input type="radio"/>	Preset Text 2	>
Presets	<input checked="" type="radio"/>	Preset Text 3	>
Presets	>	Preset Text 4	>
			

When prompted during the measuring workflow, you must select either of the preset text fields from the list.

Use Previous Value

If enabled, the previous entered value will already be filled in, when the appropriate entry keyboard appears.

Only applies when **Field Type** is set to either **Text** or **Number**.

Access

From the  **Access** menu the various users and their access levels are created and managed. This is also where the **Administrator** can log in and also change the login PIN-code.

See "[Access levels](#)" on page 66 for details about the various access levels and the associated rights.

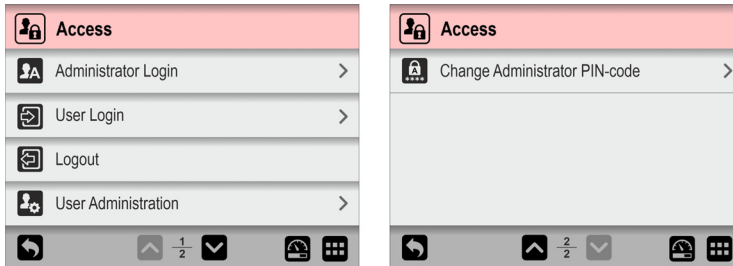



-
- 

Administrator Login Requires for a special **Administrator** PIN-code (6 digits).
From the factory the PIN-code is set to **"000000"**.
The **Administrator** PIN-code can be changed to one of your own selection - see "[Change Administrator PIN-code](#)" on page 69 for details.



For best safety and correct operation of the device, we recommend logging out of the "Administrator" feature when its use is not required.
 - 

User Login *(Only available if login is required - see "[Login](#)" on page 84 for details).*
Select **User** or login with **User ID**, whatever is required.
 - 

Log out *(Only available if login is required)*
Log out the current user, then login as a different user by selecting **User** or login with **User ID**, whatever is required.
 - 

User Administration Maintain user database.
See "[User Administration](#)" on page 67 for details.
 - 

Change Administrator PIN-code See "[Change Administrator PIN-code](#)" on page 69 for details.

Access levels

The various access levels and the associated rights are described below:



NOTE! A higher level of access always has all rights from lower access levels.

Standard Test Operator	<p>Basic user.</p> <ul style="list-style-type: none"> Can only perform tests on workflows/products marked as Standard Test. If Use State Mark is enabled in Settings -> Device the access is limited to Standard Test products/workflows marked with State = Current. Cannot change any settings.
Operator	<p>Normal user.</p> <ul style="list-style-type: none"> Can perform tests using all products/workflows with State = Current. Cannot change any settings.
Supervisor	<p>Daily administrator of products/workflows and standard users.</p> <ul style="list-style-type: none"> Has access to all products/workflows. Can create products/workflows and edit custom fields. Can create Standard Test Operator and Operator users, but not other Supervisor users. Can access the System Test and Create Test Vacuum functions from the Service -> Test & Adjustment menu. Can export measurement logs and error/event logs. Cannot change settings in the Settings menu.
Administrator	<p>Device administrator.</p> <ul style="list-style-type: none"> Can change settings in the Settings menu (except for the Service menu). Can create Supervisor users. Can remove access to Service login. Can export and import all data.
Service	<p>Service Technician.</p> <ul style="list-style-type: none"> Can access all settings in the Settings -> Service menu. Can access all functions in the Service -> Test & Adjustment menu.

Supervisor login



At start-up when user login is required and you are logged in either by selecting a user from the **User Login** list or by entering a valid **User ID** whatever is required, even users created with **Supervisor** access will also only have **Operator** access at this point.

To obtain **Supervisor** rights, you must log in again via **Main Menu** -> **Access** -> **User Login** with a valid **User ID**.

 **User Administration**

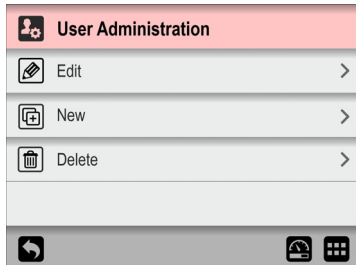
From here the user database is maintained. You can edit the settings for an existing user, create new users or delete users.



	Edit	Edit an existing user. User settings are described in <i>"New" on page 68.</i>
	New	Creates a new, blank user. See <i>"New" on page 68</i> for details.
	Delete	Delete user.

New

Creates a new, blank user. The total number of users that can be created is 50.

The screenshot shows a mobile application interface for creating a new user. At the top is a red header with a plus-in-square icon. Below it are three input fields: 'User Name' with a right-pointing chevron, 'User ID' with 'User ID' text and a right-pointing chevron, and 'Access Level' with 'Standard Test Operator' text and a right-pointing chevron. At the bottom is a grey navigation bar with a back arrow, a home icon, and a grid icon.

The following parameters can be set for a user:

User Name	A unique user name (up to 25 characters).
User ID	Unique user identification code (up to 25 characters). Both numbers and letters can be used. Use ID to login when login with User ID is required.
	 NOTE! If you forget your User ID, you should create a new (requires for Supervisor access).

Access Level	Select access level.
	<p>The screenshot shows a mobile application interface for selecting an access level. It has a red header with the text 'Access Level'. Below it are three radio button options: 'Standard Test Operator' (which is selected), 'Operator', and 'Supervisor'. At the bottom is a grey navigation bar with a back arrow.</p>

The access level determines how much you have access to in relation to creating, modifying and deleting data.

See "[Access levels](#)" on page 66 for details.

Change Administrator PIN-code

(Administrator only)

Use this function to change the PIN-code required for logging in as **Administrator**.

To change the PIN-code do the following:

1. From the  **Access** menu select  **Change Administrator PIN-code**.
This screen appears:

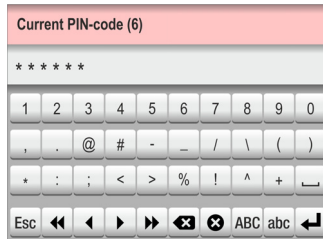

2. Enter current PIN-code (6 digits) and tap the  key.

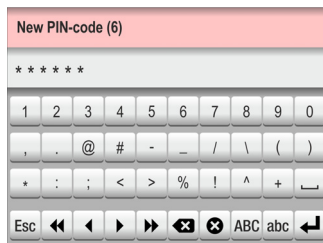

3. Enter new PIN-code (6 digits) and tap the  key.



4. Enter new PIN-code again and tap the  key.

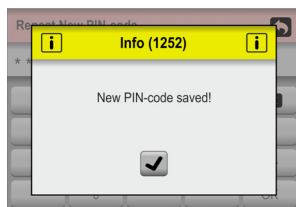



5. Tap  to confirm. PIN-code has now been changed.





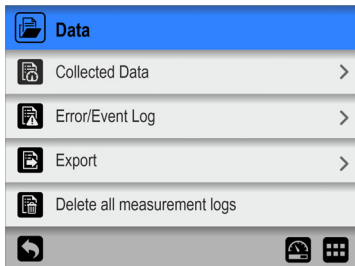

Data

From the  **Data** menu you can read out and manage measurement data for selected products and error and event log data.

The system can store log data for more than 1,000,000 tests.



The  **Data** menu holds the following items:

 Collected Data	Opens the  Collected Data screen See " <i>Collected Data</i> " on page 71 for details.
 Error/Event Log	Displays an internal log file listing the last 99 pages of errors and events. To see the complete list of errors and events you should export the logs - see " <i>Export</i> " on page 73 for details.
 Export	Opens the  Export screen See " <i>Export</i> " on page 73 for details.
 Delete all measurement logs	Use function to delete log data for all products. The action must be confirmed before the data is deleted.

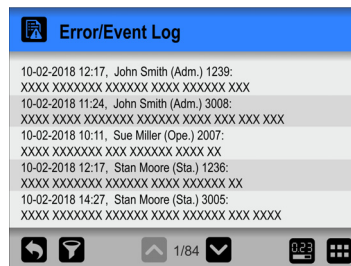

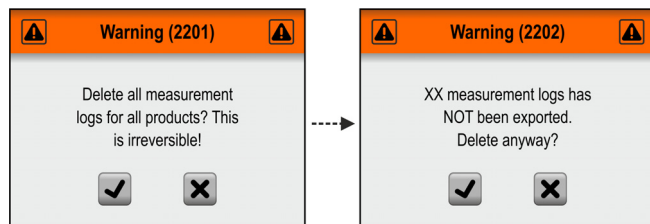

Tap the  icon to select the type of logs to be displayed (**Errors, Events, Warnings** or **All**) if required.



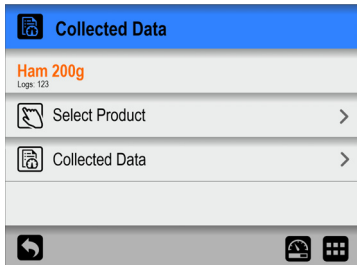

 **Collected Data**

From the  **Collected Data** screen you can read out and manage the measurement log data for selected products.



The  **Collected Data** menu holds the following items:

<p>Active product</p>	<p>The product currently selected for data management. The field also shows the current number of data logs for the product. The default selected product is always the active product (product text is orange) but any other product can be selected using the  Select Product function.</p>
<p> Select Product</p>	<p>Select product for data management. The procedure of locating and selecting products is the same as described in <i>"Select (as active)" on page 58</i> and <i>"Find and Filter" on page 61</i>.</p>
<p> Collected data</p>	<p>Displays the logged data (if any) for the currently selected product. See <i>"Collected data" on page 72</i> for details.</p>

Collected data

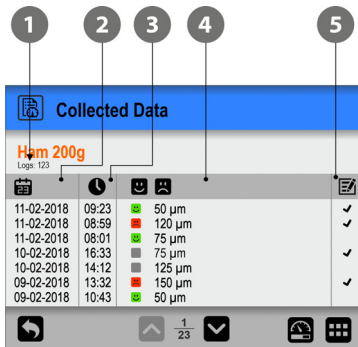

Selecting  **Collected data** from the  **Collected Data** menu will display a list of the logged measurement data for the selected product.



The list shows the following information about each log:

- 1 **Number of log entries for the selected product**
- 2 **Log date** 
- 3 **Log time** 
- 4 **Test result**  

The colored symbols indicate the following:

-  The measurement is equal to or below the leak limit setting.
Measurement is a valid measurement.
-  The measurement is higher than the leak limit setting.
Measurement is a valid measurement.
-  The measurement has been marked as invalid or an error occurred during measuring.



- 5 **Comments** 

Comments are attached to the measurement, either via custom fields or as a comment on an invalid measurement.
All custom field entries and comments are exported together with the log data.



The logged data can be exported - see *"Export" on page 80* for details.

Data logging via a local network is also possible - see *"Network Logging" on page 83* for details.

 **Export**

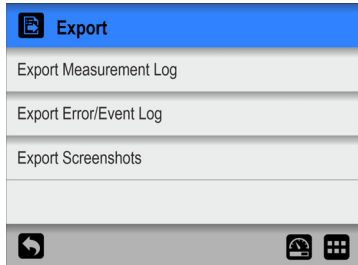
Selecting  **Export** from the  **Data** menu will display a screen showing the available export functions.



 **NOTE!** The export functions requires that you insert a USB-stick in one of the device's USB-ports (labelled ).

Export Measurement Log	Exports all measurement data logs (as text file).
Export Error/Event Log	Exports error/event logs (as text file).
Export Screenshots	Exports all screen-shots from the device's memory to a USB-stick. At the same time the screen-shots are deleted from the device. See page 21 for details about making screen-shots.

Service

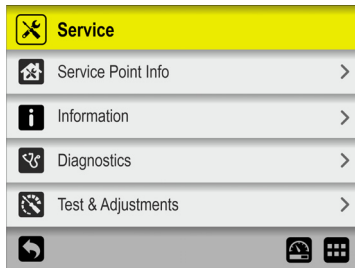

The  **Service** menu holds the following items:

Service Point Info

Displays the company information for your appointed service provider.

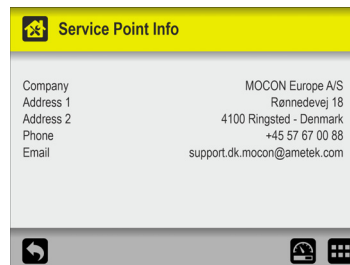

(Can be changed by a Service Technician).

Information

Opens the  **Information** screen.
See "*Information*" on page 75 for details.

Diagnostics

Opens the  **Diagnostics** screen.
See "*Diagnostics*" on page 75 for details.

Test & Adjustments

Opens the  **Test & Adjustments** screen.
See "*Test & Adjustments*" on page 76 for details.

i Information

The **i Information** screen holds general information about the device.

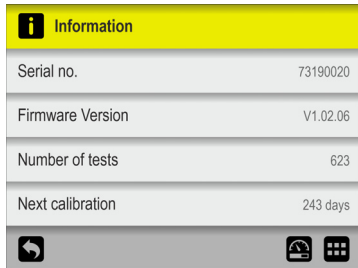

Serial no.	Shows the device’s serial number.
Firmware Version	Shows the firmware version currently installed on the device.
Number of tests	Shows the total number of tests performed.
Next calibration	Shows the number of days left until the device should be calibrated.

🔧 Diagnostics

The **🔧 Diagnostics** screen holds various internal device parameters.

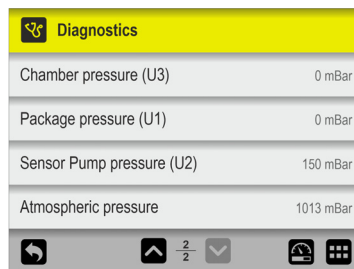
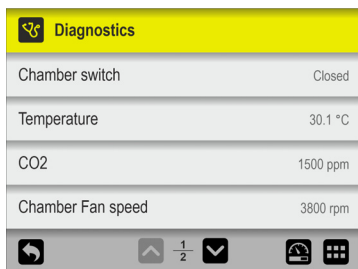

The parameters can only be read and not changed.

Chamber switch	Shows if the chamber is open or not. Can be used to check if the magnets in the sealing are placed correctly.
Temperature	Shows the temperature measured on the PCB in the device. This will always be slightly higher than the surrounding temperature.
CO2	Shows the current CO ₂ concentration in the surrounding atmosphere.
Chamber Fan Speed	Shows the current speed of the fan inside the chamber.
Chamber pressure (U3)	Shows the pressure difference between the chamber and the surrounding atmosphere. This should be close to 0 when the chamber is open.

Package pressure (U1)	Shows the pressure difference between the chamber and inside a package when package is connected to the DeltaP connector in the chamber.
Sensor Pump pressure (U2)	Shows the pressure difference between the exhaust of the sensor pump and the surrounding area.
Atmospheric Pressure	Shows the currently measured atmospheric pressure.

Test & Adjustments

The  **Test & Adjustments** functions can be used to perform various tests.

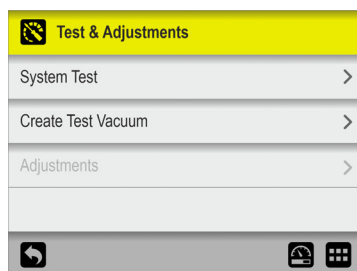

System Test	Opens the System Test screen. See " <i>System Test</i> " on page 76 for details.
Create Test Vacuum	Opens the Create Test Vacuum screen. See " <i>Create Test Vacuum</i> " on page 78 for details.
Adjustments	<i>Only available for Service Technicians.</i>

System Test

The **System Test** function can be used to test the main functions of the device.

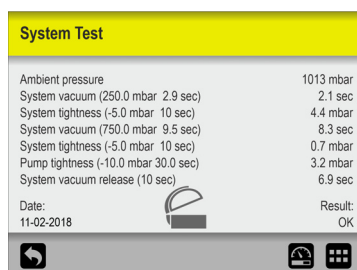

1. Close chamber to start the test.

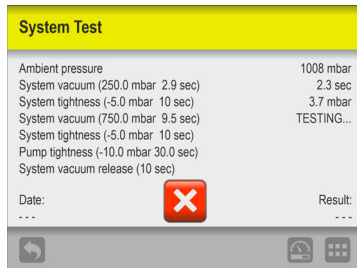

The test checks the following:

■ **Ambient pressure:**

The current ambient pressure. The limits for the test changes with the ambient pressure.

■ **System vacuum, 250 mbar:**

A delta pressure of 250 mbar should be established in the chamber within the time limit.

■ **System tightness, -5.0 mbar:**

The sample pump pumps gas from the chamber for 10 sec. During this time the delta pressure in the chamber must not have decreased 5 mbar.

■ **System vacuum, 750 mbar:**

A delta pressure of 750 mbar (starting from 250 mbar) should be established in the chamber within the time limit.

■ **System tightness, -5.0 mbar:**

The sample pump pumps gas from the chamber for 10 sec. During this time the delta pressure in the chamber must not have decreased 5 mbar.

■ **Pump tightness, -10.0 mbar:**

(LeakPointer 3+ models only)

The vacuum valve between the chamber and the pump is opened and the vacuum pump is turned off. The delta pressure in the chamber must not decrease more than 10 mbar within the time limit.

■ **System vacuum release:**

The chamber vacuum should be released within the time limit.

2. If all tests are performed without errors, the screen will show:

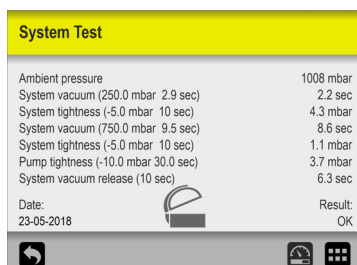

3. If one of the tests fails, the entire test procedure stops and an error message arrives.

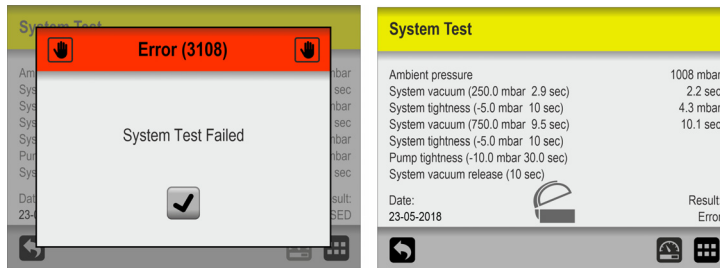

Press the button to close the error message.

On the screen you can see which test has failed and the measured value for it.

Create Test Vacuum

The **Create Test Vacuum** function can be used to create a specific vacuum in the chamber in order to find leaks or to determine a proper test pressure for a package.

The function is similar to the one that can be accessed from the product setup screen - see description in "*Product setup*" on page 30 for details about using the function.

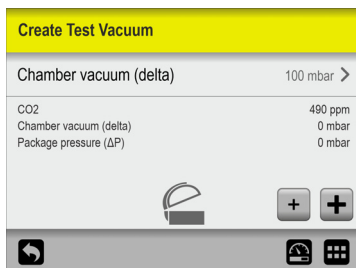





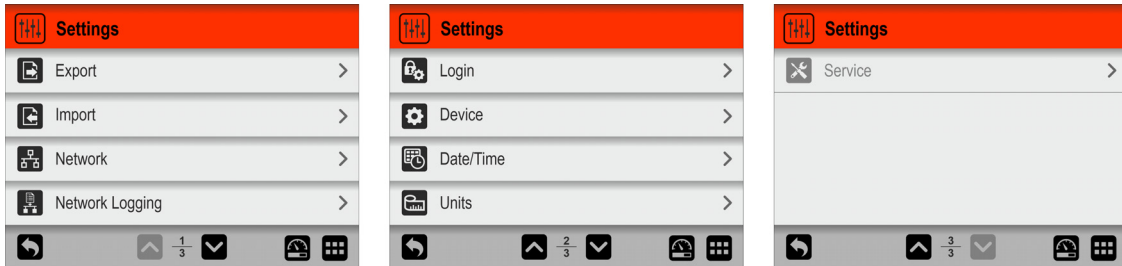













Settings



Selecting  **Settings** from the  **Main Menu** will display a menu with available set-up parameters.





The menu holds the following items:

 Export	Opens the  Export screen See <i>"Export" on page 80</i> for details.
 Import	Opens the  Import screen See <i>"Import" on page 81</i> for details.
 Network	Opens the  Network setup screen See <i>"Network" on page 82</i> for details.
 Network Logging	Opens the  Network Logging setup screen See <i>"Network Logging" on page 83</i> for details.
 Login	Opens the  Login setup screen See <i>"Login" on page 84</i> for details.
 Device	Opens the  Device setup screen See <i>"Device" on page 85</i> for details.
 Date/Time	Opens the  Date/Time setup screen See <i>"Date/Time" on page 86</i> for details.
 Units	Opens the  Units setup screen See <i>"Units" on page 86</i> for details.
 Service	Opens the  Service setup screen <i>Only available for Service Technicians.</i>

Export

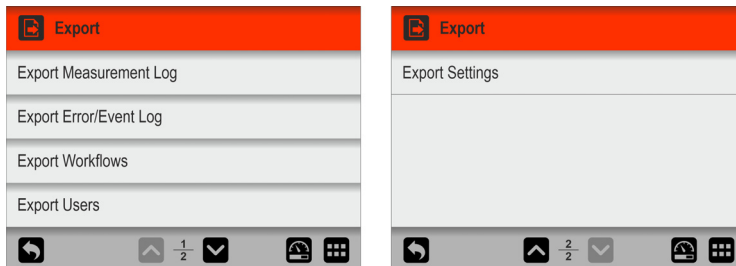
Selecting  **Export** from the  **Settings** menu will display a screen showing the various export functions.



NOTE! The export functions requires that you insert a USB-stick in one of the device's USB-ports (labelled ).



NOTE! We recommend to use the various export functions to make backups regularly so that files can be restored in case of a PCB breakdown.

The functions marked with an asterisk (*) can for example be used to clone another device.

Export Measurement Log	Exports all measurement data logs
Export Error/Event Log	Exports error/event logs
Export Workflows *	Exports the workflow database
Export Users *	Exports the user database
Export Settings *	Exports all settings from the  Settings menu

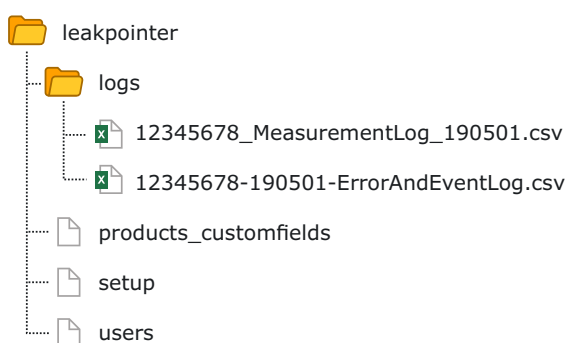

The export function creates the following folders/files on the USB-stick:





The file export format for the log files is *.csv (Comma Separated Values). This format can be imported into a spreadsheet. The actual used separator is ";" (semicolon). Measurement log files are named **<serial no.>_MeasurementLog_<date>.csv** and Error and Event log files are named **<serial no.>-<date>-ErrorAndEventLog.csv**.

Other files are exported as binary files and named **products_customfields**, **setup** and **users** respectively. These files can not be edited.

Import

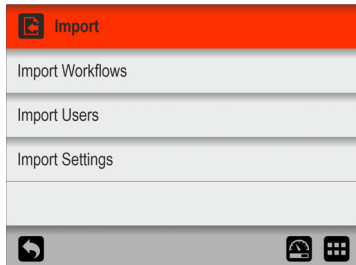
Selecting  **Import** from the  **Settings** menu will display a screen showing the various import functions.



 **NOTE!** The import functions requires that you insert a USB-stick with the required files in one of the device's USB-ports (labelled ).

The functions can for example be used to clone your device with exported data from another device.

Import Workflows	Imports a workflow database. Only new products will be imported.
Import Users	Imports a user database. Only new users will be imported.
Import Settings	Imports all settings. Current settings will be overwritten. Products, users and log files are not affected.

The import functions requires that the files are located in a folder named **leakpointer** and named as described in *"Export" on page 80*.

Network

The  **Network** screen holds the parameters for the Ethernet/LAN connection.

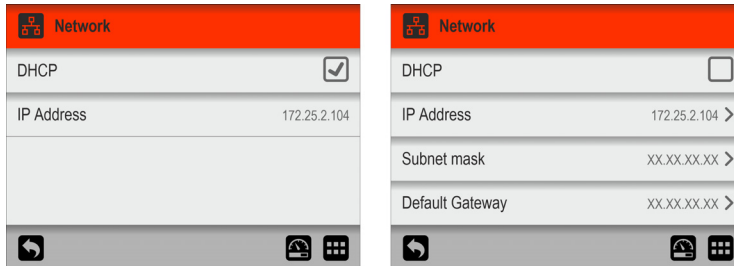

DHCP It is possible to choose between a fixed (static) IP-address or a DHCP (dynamic) IP-address, where the device's network settings are assigned from a DHCP server on the network.

DHCP is enabled as default.

Disabling **DHCP** brings up following parameters for setting up a static IP-address:

IP-address

Subnet mask

Default gateway

These parameters have to be set up to the existing network.



NOTE! Always consult your network administrator before making network settings, as incorrect settings can result in reduced or no network activity.

Network Logging

The  **Network Logging** screen holds the parameters for the network logging function. If enabled, the function sends a data string through a LAN connection for each measurement.

 **NOTE!** Always consult your network administrator before making network settings, as incorrect settings can result in reduced or no network activity.

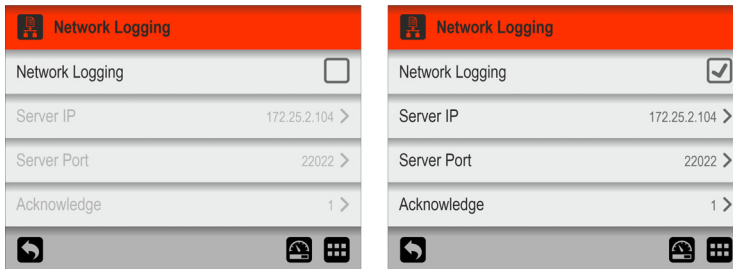

Network Logging

Select whether or not network logging is required.

Disabled = No network logging

Enabling **Network Logging** also enables the following parameters:

- Server IP** Set up an IP-address to be used for collecting log data for each measurement via LAN. This requires for setting up of a **Server Port** number as well.
- Server Port** See above.
- Acknowledge** Byte sent by the server to the device after each received log entry. Setting value to 0 will disable the function.

A TCP/IP LAN server has to be implemented to receive data. The server will listen to the port as specified above.



The protocol is an array of semicolon separated values:

"Device Serial No; Date; Time; User Name; Product Name; Product ID; Mode; Standard Test; State; Vacuum (delta); Test time; Leak limit; Hole limit; Leak gain factor; Hole size (micron); CO2 increase /ppm/s); Leak; Marked state; Error nr; Days till calibration; Invalid measurement comment; Custom field 1; Custom field 1 reply; Custom field 2; Custom field 2 reply; Custom field 3; Custom field 3 reply; Custom field 4; Custom field 4 reply;"

Login

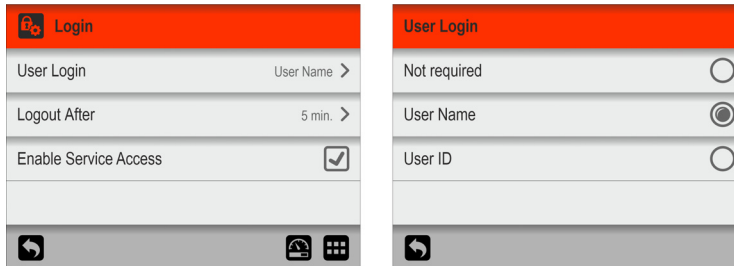
Setting up of the login function.



<p>User Login</p>	<p>You can choose between 3 types of user login:</p> <p>Not required At start-up the device initializes and when finished it changes to show the measuring screen, ready for measuring. Current user is the default  Operator.</p> <p>User Name During start-up or if changing user, you are taken to the  Access screen, where you must select  User Login and then either select a user from the list or enter a valid User ID to go to the measuring screen, ready for measuring.</p> <p>User ID</p>
<p>Logout After</p>	<p>Set the time after which the device automatically logs out if it is not in use.</p>
<p>Enable Service Access</p>	<p>Select whether or not it should be possible to log in as a user with Service access.</p>

 **Device**

The  **Device** screen holds some basic device setup parameters.

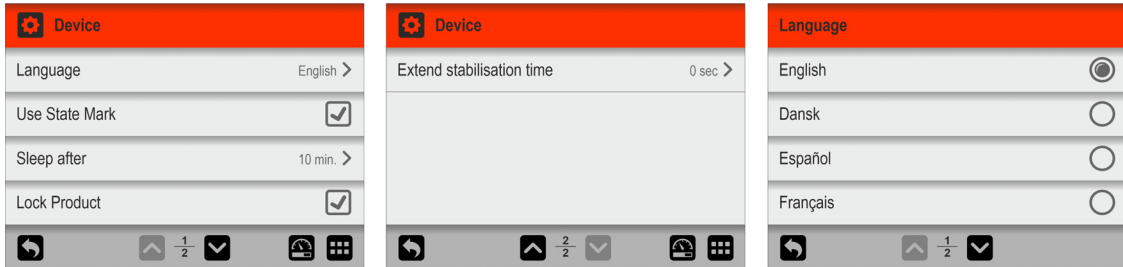

Language	When selecting a language all text throughout the menus will be displayed in this language
Use State Mark	Select whether or not the State function should be used for products/workflows. If function is disabled all products/workflows are available for users on all access levels.
Sleep After	To save energy and reduce noise, you can make the device switch to a “Sleep” mode when not in use for a period. This will cause e.g. the fan in the chamber and the sample pump to stop and the display will be dimmed. Setting value to 0 will disable the function. To “wake up” the device, simply tap anywhere on the screen.
Lock Product	When enabled, most of a product’s parameters are locked from editing when a measurement has been performed using the product.
Extend stabilisation time	If the device is used where the background CO ₂ level is relatively high, it is important that the CO ₂ level in the chamber is stable before starting a measurement. This can be obtained by extending the stabilisation period by up to 15 sec. (default setting = 0).

Date/Time

The  **Date/Time** screen holds the time and date setup parameters.

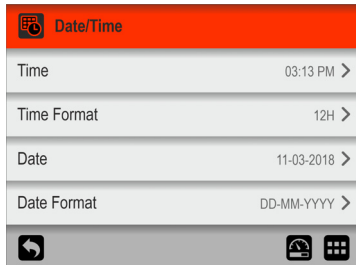

Time	Setting of current time (hh:mm)
Time format	Setting of time format (12h or 24h)
Date	Setting of current date (using Date format)
Date format	Setting of date format (DD/MM/YYYY or MM/DD/YYYY)

Time, Date and **Date format** are related to the real time clock setting in the device.
The settings will have effect in all displays showing time and date.

Units

The  **Units** screen holds the various setup parameters for output formats and units.

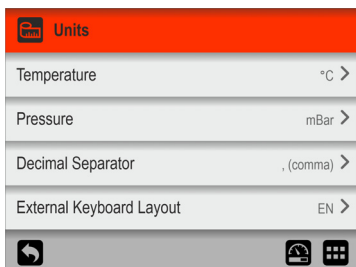

Temperature	Setting of temperature read-out unit (°C or °F)
Pressure	Setting of gas pressure read-out unit (mBar, PSI or mmHg)
Decimal separator	Select whether decimal values should use “. (dot)” or “, (comma)” as decimal point.
External Keyboard Layout	Select keyboard layout for an external keyboard connected via USB (English, Dansk, Español, Francais, Deutsch, Italiano)

5. Technical Information

Technical specifications

Mechanical specifications

Dimensions

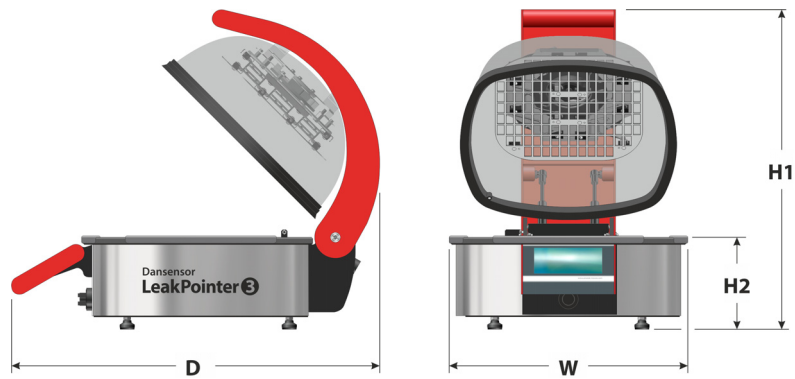

	W	D	H1	H2
LeakPointer 3	400 mm (15.7")	617 mm (24.3")	543 mm (21.4")	155 mm (6.1")
LeakPointer 3+	555 mm (21.9")	812 mm (32")	751 mm (29.6")	230 mm (9")

Weight	Unpacked	LeakPointer 3:	Approx. 20 kg (44 lbs)
		LeakPointer 3+:	Approx. 50 kg (110 lbs)
	Crated	LeakPointer 3:	Approx. 30 kg (66 lbs)
		LeakPointer 3+:	Approx. 85 kg (187 lbs)

IP Class	IP20
-----------------	------

Ambient temperature	Operation:	+2 to +35 °C
	Storage:	-20 to +60 °C

Ambient humidity	Operation:	+2 to +25 °C:	10 - 90 % RH, non condensing
		+25 to +30 °C:	10 - 70 % RH, non condensing
		+30 to +35 °C:	10 - 50 % RH, non condensing
	Storage:	< 95 % RH, non condensing	

Ambient pressure	Operation:	900 - 1050 mbar
-------------------------	------------	-----------------

Operation altitude	< 2000 m (6500 ft)
---------------------------	--------------------

Ambient CO₂	Max. 4500 ppm, recommended < 1500 ppm
-------------------------------	---------------------------------------

Electrical specifications

Power supply	LeakPointer 3:	100 - 264 VAC + PE, 47- 63 Hz Fuse 5x20 mm, 2 AT
	LeakPointer 3+, 115V:	103 - 127 VAC + PE, 57- 63 Hz Fuse 5x20 mm, 10 AT
	LeakPointer 3+, 230V:	207 - 253 VAC + PE, 47- 53 Hz Fuse 5x20 mm, 6.3 AT
Power consumption	LeakPointer 3:	Max. 50 Watt
	LeakPointer 3+, 115V:	Max. 900 Watt
	LeakPointer 3+, 230V:	Max. 900 Watt

Connectivity

USB	2 x USB (2.0 - Type A), max. current 500 mA For connection of bar-code scanner, printer and memory stick
Network/LAN	RJ-45 Ethernet 10/100 Mbit/s, DHCP client or fixed IP

Compressed air supply

(LeakPointer 3 only)

Hose dimensions	Ø6/4 mm ¹
Air supply pressure	5.5 ± 0.5 Bar (80 ± 7 psi)
Air consumption	Approx. 33 l/measurement, max. 162 l/min
Air quality	Dry, clean and free from oil Compliant with DIN ISO 8573-1:2010 [6:4:4] ²

¹ Ensure that the used hose type is appropriate for the required pressure

² See "Filter recommendations" on page 17

CO₂ Sensor

Sensor type	Non Dispersive Infra Red (NDIR), single beam
Sensor life	Approx. 3 years

Leak measuring

Package types Flexible and rigid packages, single or multiple
Min. CO₂ content of 10%¹

Package Sizes

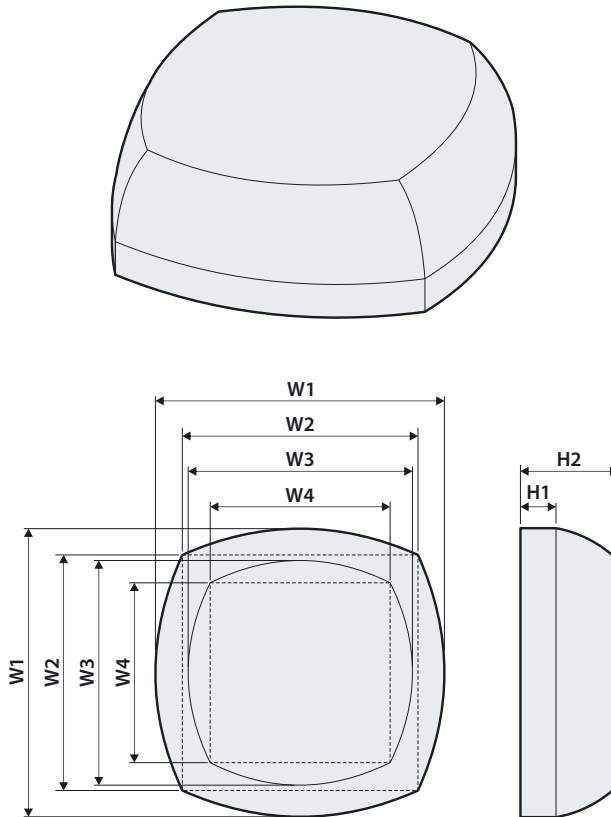

	LeakPointer 3 with PackFix	LeakPointer 3 without PackFix	LeakPointer 3+ with PackFix	LeakPointer 3+ without PackFix
W1	325 mm (12.8")	325 mm (12.8")	465 mm (18.3")	465 mm (18.3")
W2	265 mm (10.4")	265 mm (10.4")	378 mm (14.9")	378 mm (14.9")
W3	295 mm (11.6")	268 mm (10.6")	420 mm (16.5")	363 mm (14.3")
W4	241 mm (9.5")	215 mm (8.5")	340 mm (13.4")	291 mm (11.5")
H1	40 mm (1.6")	40 mm (1.6")	40 mm (1.6")	40 mm (1.6")
H2	86 mm (3.4")	110 mm (4.3")	117 mm (4.6")	155 mm (6.1")

Measuring cycle time	10 - 35 sec.
Test vacuum	LeakPointer 3: 50 - 750 mbar ² LeakPointer 3+: 50 - 800 mbar ²
Leak size	Down to 50 µm hole ³ Read-out as µm or ppm/s

¹ Depends on package type, delta pressure and hole size

² There must be min. 150 mbar abs. pressure left in the chamber

³ Depends on package type, delta pressure, package CO₂ content, etc.

User Interface

Display type	5.7" colour touch display with backlight QVGA (640 x 480 pixels) 4096 colours
Functions	Multi language text and icons Supported languages: EN, DA, ES, FR, DE, IT

Conformity

- CE marking requirements for Europe
- China RoHS Phase II marking requirements, EFUP=15 years

Consumable parts and options

Ordering items

When ordering any of the below listed items please state carefully the item number, the item specification and the number of items wanted and send the order to your spare parts dealer.

Available User Guides

All user guides are available on:

- USB, User guides, LeakPointer 3, Cpl..... P/N 380063

Consumable parts

- Needle kit Ø0,8x16mm (10 pcs.) Ser. Cpl P/N 340532
- Needle kit Ø0,4x12mm (10 pcs.) Ser. Cpl P/N 380230
- Septum, ø15mm white/hard (100 pcs) Ser. Cpl..... P/N 220235
- Septum, ø15mm white/hard (1000 pcs) Ser. Cpl. P/N 220236
- Measure hose, delta P, LP 3 Ser. Cpl..... P/N 380127

Options/Accessories

- Option, Barcode Scanner w. cable, Ser. Cpl..... P/N 301189
- Option, Leak Simulation Kit, Ser. Cpl..... P/N 341040
- Option, PackBase, 20x2, 250x250mm w/feet, Ser. Cpl. P/N 380151
- Option, PackBase, 20x2, 350x350mm w/feet, Ser. Cpl. P/N 390018
- Option, PackFix, 200N, LP3+, Ser. Cpl..... P/N 390161
- Option, PackFix, 100N, LP3, Ser. Cpl..... P/N 390162
- Option, PackTray, LP3+, Ser. Cpl. P/N 390163
- Option, Leak Simulation Kit, 100 micron, Ser. Cpl..... P/N 390169

Printer

All measurement data can be printed continuously on a connected USB-printer.

MOCON Europe A/S does not offer printers, but we have tested the following printer and can therefore recommend this:

Epson TM-T20II Series



NOTE! If you want to connect another printer model, it must be compatible with the ESC/POS™ standard.

Appendix

Safety and handling instructions



WARNING! Personnel operating and maintaining the device must be familiar with all aspects of its operation and be proficient in maintenance. Such personnel should review the following precautions to promote safety awareness. Failure to follow the safety instructions could result in fire, electric shock, injury, or damage to Dansensor® LeakPointer 3 or other property.



NOTE! The manufacturer cannot be held responsible for any damage caused by incorrect operation or maintenance of the device.

Handling and maintenance

- Be sure to disconnect electrical power and unplug the unit before performing any cleaning or maintenance.
- When operating or maintaining the equipment always obey the relevant rules and regulations for workers safety.
- Handle the device with care. It is made of metal, glass, and plastic and has sensitive electronic components inside.
- The device can be damaged if dropped, burned, or crushed, or if it comes in contact with liquid.
- Do not use a damaged device, such as one with a cracked screen, as it may cause injury.
- Do not cover the device with a cloth or piece of plastic to protect it from dust, as this prevents free air circulation around the device and might lead to overheating.
- Do not expose the device to heavy moisture or heat and keep it away from direct sunlight.

Repairing

- Don't open the device and do not attempt to repair it yourself, as this may damage it or may cause injury to you.
- If device is damaged, malfunctions, or comes in contact with liquid, contact your authorized MOCON Dansensor A/S service provider.

Cables

- If using other third-party cables and power plugs, make sure that they are compatible with USB 2.0 or later, and that the power supply and plugs are compliant with applicable country regulations.
- Replace damaged cables immediately. Using damaged cables can cause fire, electric shock, injury, or damage to the device or other property.

Explosive atmospheres

- Using the device in any area with a potentially explosive atmosphere, such as areas where the air contains high levels of flammable chemicals, vapours, or particles, may be hazardous. Obey all signs and instructions.

Cleaning

- Never use hard tools or abrasive materials when cleaning any part of the device.
- Never use cleaning agents containing chlorinated solvents or acetic or phosphoric acid. These constitute a health hazard and could damage the device.
- Avoid getting moisture in openings.
- When using compressed air for cleaning of e.g. hoses or needles, make sure that items have been disconnected from the device and use safety goggles.

Using connectors, ports, and buttons

- Never force a connector into a port or apply excessive pressure to a button, because this may cause damage that is not covered under the warranty.
- If the connector and port don't join with reasonable ease, they probably don't match. Check for obstructions and make sure that the connector matches the port and that you have positioned the connector correctly in relation to the port.

Operating/storing temperatures and humidities

- The device is designed to be operated and stored in the temperature and humidity ranges as specified in "*Mechanical specifications*" on page 87. The device can be damaged if stored or operated outside of these ranges.
- If the device has been stored in a cold location and then moved to a warmer location, at least one hour of acclimatisation is required before switching it on.
- If the device is operated in a cold and high humidity environment it is advisable to let it heat up for 5-10 minutes after it has been switched on.

Toxic and Hazardous Substances or Elements

(For China RoHS compliance)

See table on the next page.

LeakPointer 3/LeakPointer 3+
Hazardous Substances
有害物质

Component name (组分名称)	Lead 铅 (Pb)	Mercury 汞 (Hg)	Cadmium 镉 (Cd)	Hexavalent Chromium 六价铬离子 (Cr(VI))	Polybrominated Biphenyls 多溴化联苯 (PPB)	Polybrominated Diphenyl Ethers 多溴化二苯醚 (PBDE)
Chamber assembly (腔内组件)	X	0	0	0	0	0
Fan assembly, chamber (风扇组件, 腔内)	X	0	0	0	0	0
PackFix assembly (PackFix 组件)	X	0	0	0	0	0
Gas distrib. plate and fanguard assembly (气体分配盘和风扇网罩组件)	0	0	0	0	0	0
Metal enclosure, plates, spacers between plates and feet (金属外壳, 板, 板间垫片以及支脚)	0	0	0	0	0	0
Gas springs (气弹簧)	0	0	0	0	0	0
Block, pressure, chamber/delta P assembly (块, 压力, 腔内/压差组件)	X	0	0	0	0	0
Pump (sensor) assembly (抽气泵 (传感器) 组件)	0	0	0	0	0	0
Pressure sensor block/PCB assembly (压力传感器块/PCB 组件)	X	0	0	0	0	0
CO2 sensor and housing (二氧化碳传感器和外壳)	X	0	0	0	0	0
Proximity sensor with bracket (近距离传感器, 带支架)	0	0	0	0	0	0
PSU with fittings and housing (PSU, 带配件和外壳)	X	0	0	0	0	0
Valve - Air pressure in (阀门 - 内部气压)	0	0	0	0	0	0
PCB main assembly (PCB 主要组件)	X	0	0	0	0	0
Net filter assembly (网过滤器组件)	0	0	0	0	0	0
Valve/ejector assembly (LP3) (LP3 阀门/喷射器组件)	0	0	0	0	0	0
Valve assembly (LP3+) (LP3+ 阀门组件)	X	0	0	0	0	0
Back plate assembly (LP3) (LP3 背板组件)	X	0	0	0	0	0
Back plate assembly (LP3+) (LP3+ 背板组件)	0	0	0	0	0	0
Cable trays (电缆槽)	0	0	0	0	0	0
Display unit with PCB and display enclosure (显示装置, 带 PCB 和显示器外壳)	0	0	0	0	0	0
Relay and RC coupling (LP3+) (LP3+ 继电器和 RC 耦合)	0	0	0	0	0	0
Vacuum pump (真空泵)	X	0	0	0	0	0

This table is prepared in accordance with the provisions of SJ/T 113364. 本表格按照 SJ/T 113364 的规定编制。

O: It indicates that the content of the hazardous substance contained in all of the homogeneous materials for this part is below the limit requirements of GB/T 26572.
 代表此部件中所有同质材料的有害物质含量均低于 GB/T 26572 标准所要求的含量。

X: It indicates that the content of the hazardous substance contained in at least one of the homogeneous materials used for this part is above the limit requirements of GB/T 26572.
 代表此部件中至少一种同质材料的有害物质含量超过 GB/T 26572 标准所要求的含量。

All "X" in the Lead (Pb) column comes from the usage of brass parts. "Lead (Pb)" 这列中的所有 "X" 均是由于使用了黄铜部件。

This blank page has been inserted to enable double sided printing of the document!



MOCON Europe A/S
Rønnedevej 18
4100 Ringsted, Denmark
Tel +45 57 66 00 88
info.dk.mocon@ametek.com
www.ametekmocon.com