



Cermax Portable Dewpointmeter

This high specification portable hygrometer with a long battery life gives a wide operating range, extremely fast response and a host of user-definable features such as data logging and multiple display options

- Easy to use
- Super-fast response
- High accuracy and repeatability
- User friendly display with data logging facility
- Lightweight construction
- Long battery life
- Intrinsically safe version*



The Most Complete Portable Hygrometer

Packed full of features and with a performance to match, Cermax sets the standard amongst portable hygrometers. Delivered with a traceable calibration to ± 1 °C dew point accuracy, Cermax is ready to use, out of the box. It is extremely easy to operate, yet allows the advanced user to perform more complex functions, like pressure compensation, range selections, input scaling, data logging, etc. No other instrument looks or performs like Cermax.

Easy Operation

Cermax is fully self-contained - no external services are required. Simply connect the sample gas to the Swagelok® inlet port, turn on the power and within seconds Cermax is ready to display the measured dew point of the sample gas under test.

Extremely Fast Response

Our users always rate a fast speed of response as the key feature of a portable hygrometer. Cermax has been designed particularly with this in mind. With an inherently fast Ceramic Moisture Sensor at its heart and a minimum volume stainless steel sample housing, Cermax has a head start on the competition. Add to this Cermax's user selectable field operation mode that allows

even ppm level measurements to be made in a few minutes and the result is a world-class hygrometer with superior performance.

High Accuracy and Repeatability

The combination of advanced sensor technology and measurement circuitry give Cermax a standard measurement range from -100 to +20 °C dew point with indication down to -120 °C and up to +30 °C dew point. Cermax offers a measurement accuracy of ± 1 °C dew point in the range +20 to -60 °C dp and ± 2 °C dew point in the range -100 to -60 °C dp. Resolution is 0.1 °C dew point across the entire calibration range.

User Friendly Display

Cermax's programmable display interface powers up to give an almost instant display of the measured dew point. Its clear LCD display can easily be set, using the intuitive drop-down menu, to show a wide variety primary and secondary measurement data, including dew point in °C, °F and K; parts per million by volume and weight for a number of gases, pounds per million standard cubic feet and percentage relative humidity. System pressure or temperature can be input to the instrument to provide active compensation.

* See separate datasheet for details

Data Logging Facility

Built into the instrument is a logging system that can store up to 10,000 measurement points. The logger will store both dew point and the second process variable (temperature or pressure), along with tag and time information. Logging start time, interval and test duration are all selected from the instrument's drop down menu. Once the log has been taken, data can be downloaded onto a PC using Windows™ Terminal or a similar data transfer program.

Lightweight Construction

Weighing a total of 3 kg, Cermax is one of the lightest portable instruments available. This is not, however, at the expense of robustness. The strong moulded polyurethane carry case gives

the optimum combination of physical strength and low mass and is practical too, giving an IP65 protection rating. An optional woven carry bag is ideal for storage of sampling system, pipework etc and for transportation when Cermax is not in use.

Long Battery Life

Cermax uses a sealed rechargeable battery pack which gives an average usage time of more than 8 hours between charges, at normal room temperature. The battery pack is easily removable and spare battery packs are available so that the instrument can be permanently operational, if required.

Charging can be achieved either by removal of a battery pack or via the integral charger jack socket.

Technical Specifications

Gas wetted parts	316 stainless steel
Gas connections	1/8" Swagelok® inlet and outlet couplings
Display	240 x 64 dot matrix LCD
Range	Calibrated from -100 to +20 °C dew point; readings to -120 and +30°C dew point
Accuracy	±1 °C from -60 to +20 °C dew point; ±2 °C from -100 to -60 °C dew point
Resolution	0.1°C dew point (3 significant figures for all other units)
Units	°C, °F, K dew point; ppm _V ; ppm _W for air, N ₂ , H ₂ , SF ₆ , CO ₂ , natural gas; gm ⁻³ (natural gas); Lb/mmscf (natural gas)
Secondary input	0-20 mA or 4-20 mA for temp or pressure
Data storage	Up to 10,000 samples of primary and secondary variable, time and date stamp and ident number
Communications	RS232C

Power	Internal re-chargeable battery pack (removable) charged by external AC powered charger (supplied). 8 hours normal operation between charges.
Case	Custom polyurethane case with integral padded carry handle
Dimensions	250W x 300D x 150H mm approx
Weight	3 kg
Ingress protection	IP65 (NEMA 12)
Operating temp	-20 to +50 °C
Storage temp	-65 to +65 °C
Operating pressure	30 MPa (max)
Flow rate	0.5 to 5 Nlmin ⁻¹
Optional extras	Carry bag; shoulder strap; sampling system; spare battery pack

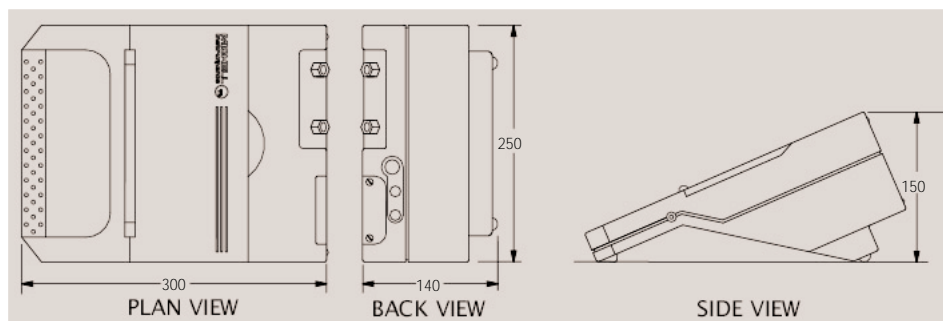

Dimensions mm



Michell Instruments Ltd, Nuffield Close, Cambridge CB4 1SS UK
 Tel: +44 (0)1223 434800 Fax: +44 (0)1223 434895
 e-mail: info@michell.co.uk www.michell.co.uk

