



Cermet II Hygrometer

A full specification on-line hygrometer for the measurement of dew point in air and process gases, with wide operating range and multiple display options

- User-friendly programmable monitor
- Wide measurement range: -100 to +20 °C dew point
- High accuracy - ± 1 °C dew point
- Analogue, digital outputs and alarms
- Extreme flexibility
- Intrinsically safe version available*



Complete On-Line Dew Point Measurement

Cermet II is the intelligent choice for reliable on-line measurement of moisture in virtually any gas, flammable or non-flammable, inert or corrosive across many applications. Cermet II combines Michell's Advanced Ceramic Moisture Sensor and a clever monitor unit that can be sited up to 1200 metres apart. Whilst Cermet II is so simple to use, it has such power and flexibility that it can be applied to almost any humidity measurement application. The instrument can display measurement units in °C or °F dew point, ppmV, Lb/mmscf or gm^{-3} across the measurement range -100 to +20 °C dp at pressures up to 30 MPa and allows active pressure compensation by means of a pressure signal input via the pressure transducer (supplied as an optional extra).

Cermet II Monitor

The Cermet II Monitor is a fully self-contained display system in an 1/8 DIN panel mounting case that indicates the measured humidity parameter and performs pressure compensation (if required). Cermet II also provides current and digital outputs and two 10 A alarm relays. It is protected to IP54 and can be supplied to special order with a front panel giving an IP66 rating. Its operating temperature range is -20 to +50 °C.

Cermet II Sensor

The Cermet II Sensor uses Michell's Advanced Ceramic Moisture Sensor technology with embedded intelligence. This smart sensor has a measurement range of -100 to +20 °C dp at pressures up to 30 MPa and offers a startling measurement accuracy of better than 1°C dp from -60 to +20 °C dp. Below -60 the accuracy is an impressive ± 2 °C dp. The inclusion of an on-board processor in the sensor electronics gives it the power to perform beyond expectations. This provides total confidence, reliability and interchangeability of sensors. Cermet II's sensor is designed to meet the rigours of industrial applications and to perform in harsh environments. Constructed in stainless steel, the sensor is also protected to IP65 and has an operating temperature range of -40 to +60 °C dp.

Extreme Flexibility

The dew point of any gas will vary with its line pressure. Cermet II can compensate for these variations either by the use of a live pressure transducer input, or by the use of a pressure factor calculation input via the instrument front panel.

For control of external devices Cermet II is supplied as standard with two 10 A/240 V c/o, fully user configurable, alarms. These

* See separate datasheet for details

can be set over the full operating range of the instrument, with variable hysteresis for any chosen engineering unit. The alarms can also be configured to flag sensor or cable fault conditions. A further two alarms can be added if required.

Also as standard, Cermet II is supplied with a 4-20 mA output, which is fully configurable for range and scale. In addition a 2-way RS232 digital signal is provided which gives full data access to the user. Optionally a 0-10 V configurable analogue output can be specified, as can an RS485 2-way digital port.

Intrinsically Safe Version*

The Cermet II Monitor, when combined with Michell's Transmet IS Dewpoint Transmitter, is the ideal solution for measurement

and display of dew point in a hazardous gas. The Cermet II Monitor must of course be located in a designated safe area.

Applications

Cermet II can provide the solution to both energy management and quality assurance in the supply of compressed air from heat regenerative, adsorption dryers. The durability of the Advanced Ceramic Moisture Sensor comes to the fore in applications such as pipeline drying using vacuum and dry gas purging techniques. The resilience of the Cermet II Sensor in potentially corrosive atmospheres provides the answer to moisture control in refinery catalytic reformer recycle gas and many other petrochemical applications.

Technical Specifications

SENSOR

Gas wetted parts	316 stainless steel
Mounting thread	5/8" UNF (parallel)
Sensor body	Stainless steel
Ingress protection	IP65 (NEMA 12) with standard connector, (IP66 (NEMA 4) with optional moulded connector)
Range	Calibrated from -100 to +20 °C dew point
Operating temp	-40 to +60 °C (compensated over -20 to +40 °C)
Accuracy	±1 °C from -60 to +20 °C dew point; ±2 °C from -100 to -60 °C dew point
Resolution	0.1 °C from -80 to +20 °C dew point; 1.0 °C from -100 to -80 °C dew point

INSTRUMENT

Measurement units	°C, °F dew point; ppm _v with user selectable range and resolution; Lb/mmscf range dependent on pressure (natural gas); gm ⁻³ (natural gas)
Secondary measurement variable	Pressure via external transducer 0-30 MPa. Completely user configurable for any industry standard transducer. Automatic compensation for ppm _v , Lb/mmscf and gm ⁻³ ranges
Power supply	Universal 85 to 265 V AC; 90 to 370 V DC
Ingress protection	IP54; IP66 (NEMA 4) for front panel only with optional cover

Operating temp	-20 to +50 °C
Relays	2 off 10 A/240 V c/o fully user configurable: can accommodate full range for selected engineering unit + sensor fault alarm functions
Outputs: analogue	4-20 mA fully user configurable and scaleable for range
digital	RS232: provides 2-way communication - full data access to user + total availability of all set-up and configuration

INSTRUMENT OPTIONS

Power supply	18 to 36 V AC; 9 to 60 V DC
Relays	1 or 2 further 5 A relays (max 4 in total) n/o type fully user configurable: can accommodate full range + full unit choice + sensor fault alarm functions
Outputs: analogue	0-10 V fully user configurable and scaleable for range
digital	RS485: provides 2-way communication - full data access to user + total availability of all set-up and configuration
Cable	Standard 2 metres (1200 metres max)

CERMET II IS (VARIATIONS)

Sensor	Transmet IS
Additional PSU	For Transmet IS. 24 V DC clip-on rail type
Barriers	2 galvanic isolation type
Instrument	As above + analogue input board

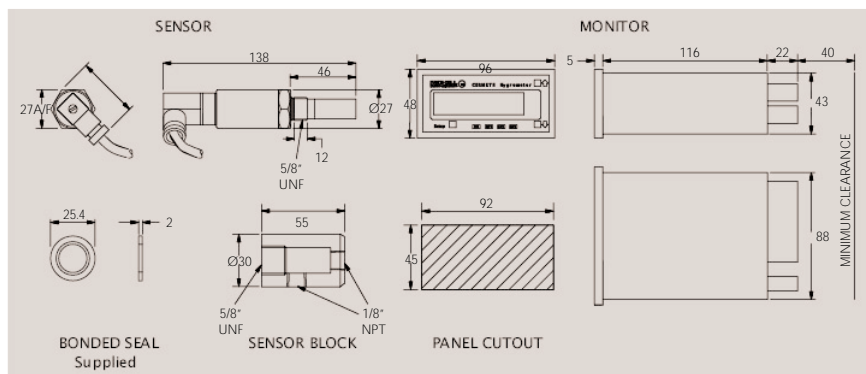

Dimensions mm



0179



Q6284

