



OX-TRAN[®] MODEL 2/28 H **OXYGEN PERMEATION ANALYZER**

High Throughput OTR Testing for Barrier Films

AMETEK[®]

mocon[®]

MAXIMIZE EFFICIENCY

OTR Barrier Measurements... Done Right.



High Throughput Oxygen Permeation Analyzer

The OX-TRAN 2/28 H Oxygen Permeation Analyzer is designed for laboratories that routinely perform a high quantity of Oxygen Transmission Rate (OTR) tests. With its unique four cell capability it can test four barrier samples at the same time, providing twice the throughput of traditional OTR instruments. It shares many of the same ease-of-use and automated testing features as the popular OX-TRAN 2/22 series permeation analyzers, with additional software features to improve laboratory efficiency. The QC Test Mode simplifies routine testing for the operators while the Conditioning Test Mode decreases overall testing time. These unique test modes can dramatically increase the efficiency and overall testing capacity of your lab making it the perfect solution for the busy QC lab supporting production operations.

Dual Film Cartridge

This innovation from AMETEK MOCON combines two test cells into one cartridge. Similarly sized to the current test cartridge, this single cartridge can test two film samples at the same time. The new design has a standard 50 cm² testing area, and our exclusive TruSeal[®] in both the upper and lower cells. The TruSeal design utilizes two seals and flushes gas between them to prevent ingress into the test area. This reduces background levels, improves repeatability, and reduces the need to run individual zero.

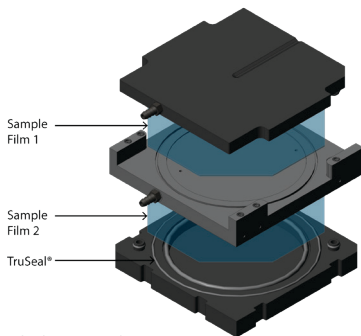

Dual Film Cartridge

High Capacity

The high throughput model with four cells has the same compact footprint as our other permeation analyzers, with the testing capacity of more than twice of the older legacy models. The Conditioning Test Mode further increases the instrument testing throughput by phasing the exam times to provide convergence data in as low as 1/2 the time compared to normal testing mode.

Coulox Sensor Technology

Using a patented coulometric sensor, the Coulox Sensor provides the most precise and repeatable oxygen permeation data available on the market today. It is the basis for the ASTM standard D3985, requires no calibration, and is the only sensor proven to meet its precision and bias requirements through independent third-party testing.



Coulox[®] Sensor

High Throughput

- 4 test cells in one instrument
- Removable horizontal film cartridges
- Short exam times
- Conditioning Test mode

Low Cost

- Get 4 cells at a comparable price to many 2 cell analyzers
- Lower maintenance cost per cell
- Coulox sensor provides longer life than other coulometric sensors

SIMPLIFIED RESULTS

User Friendly

The QC Test mode provides operators the real time status of each test by displaying the target and failure limits while tests are being run. Test methods for commonly performed tests can be set up and stored by an administrator. With a simple touch of a button operators can recall and start test methods in seconds. Final test reports clearly display the results of the test as Green (Pass), Yellow (Warning) or Red (Fail) eliminating the need to look up the target values and meaning for each test performed.

The Conditioning Test mode option allows phasing of tests by prioritizing the examinations on samples as they approach convergence while other samples are being conditioned. This provides results in less time than normal sampling mode, helping to increase the throughput of the analyzer.

Applications

The OX-TRAN 2/28 H is designed for quality control laboratories where abbreviated OTR testing is performed. Due to its simplified operation it is best suited for routine testing at set conditions. Target application is QC OTR testing of barrier film samples in dry conditions from 20° to 40°C.

This analyzer offers the ability to perform triplicate testing, along with a reference film with the same test. The option to run a known standard as a control improves confidence in the results. Whether you need to conform to triplicate standards, or just want to make sure you have consistent results, the 2/28 H can meet your needs.

QC Test mode allows upper and lower warning and failure limits to be set for stored test methods

QC Test mode graphically displays exam results within the target limits in real time

QC Test mode displaying exam results above target limits

Conditioning Test mode option for reduced time for convergence data

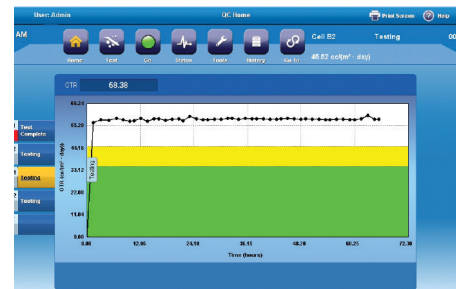
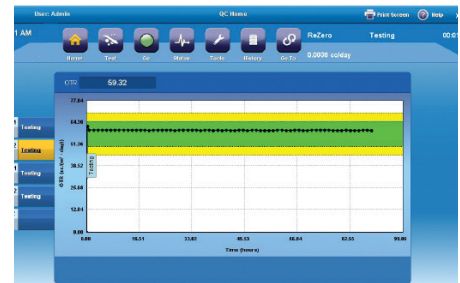

Easy to Use

- QC Test mode
- Starts tests in a single button
- Test results gives Pass, Fail or Warning
- Easily see real time test status vs target

Next Generation Features

- Large touch screen (Optional)
- Fully automated exams
- Removable test cartridges
- TruSeal gas flushing
- Automatic sensor protection

Warranty

- Full 100% parts and workmanship warranty for 12 months
- Exclusive 4-year warranty on the Coulox sensor

OX-TRAN 2/28 H SPECIFICATIONS

Industry Standards

- ASTM D3985
- ASTM F2622
- ISO CD 15105-2
- JIS K-7126-B
- DIN 53380-3
- GB/T 19789-2005

Conformance Standards

- CE, UL, CSA Safety Compliance

Performance Specifications

Test Temperature Range	20°C to 40°C ± 0.2°C
Controlled RH Testing Ranges	0% only
Maximum Film Thickness	Up to 20 mil, 0.5 mm
Carrier Gas	Nitrogen/Hydrogen Mix (98%/2%)
Test Gas	100% Oxygen (99.9% pure)

Technical Specifications

Models		Test Ranges		Resolution	Repeatability
		cc/(m ² • day)	cc/(100 in ² • day)	cc/(m ² • day)	cc/(m ² • day)
2/28 H	Normal (50 cm ²)	0.05 to 200	0.003 to 12.9	0.02	0.02 or 1%*
	Masked (5.0 cm ²)	0.5 to 2000	0.03 to 129	-	-

Connectivity

- Ethernet Port
- 2 USB Ports
- PERM-NET Lite™ for remote monitoring

Dimensions & Weight

Depth: 23" or 58,0 cm
 Width: 12" or 30,4 cm
 Height: 15.5" or 39,4 cm
 Weight: 95 lbs. or 43,1 kg

Accessories

- PermWare™ software is available to collect and manage test data
- Additional cartridges allow samples to be prepared and staged for a quick change out to increase efficiency
- 10" color touch-screen